

# LITIX™ Basic

TLD1326EL

3 Channel High-Side Current Source



<b>Package</b>	PG-SSOP-14
<b>Marking</b>	TLD1326

## 1 Overview

### Applications

- Exterior LED lighting applications such as tail/brake light, turn indicator, position light, side marker,...
- Interior LED lighting applications such as ambient lighting, interior illumination and dash board lighting.

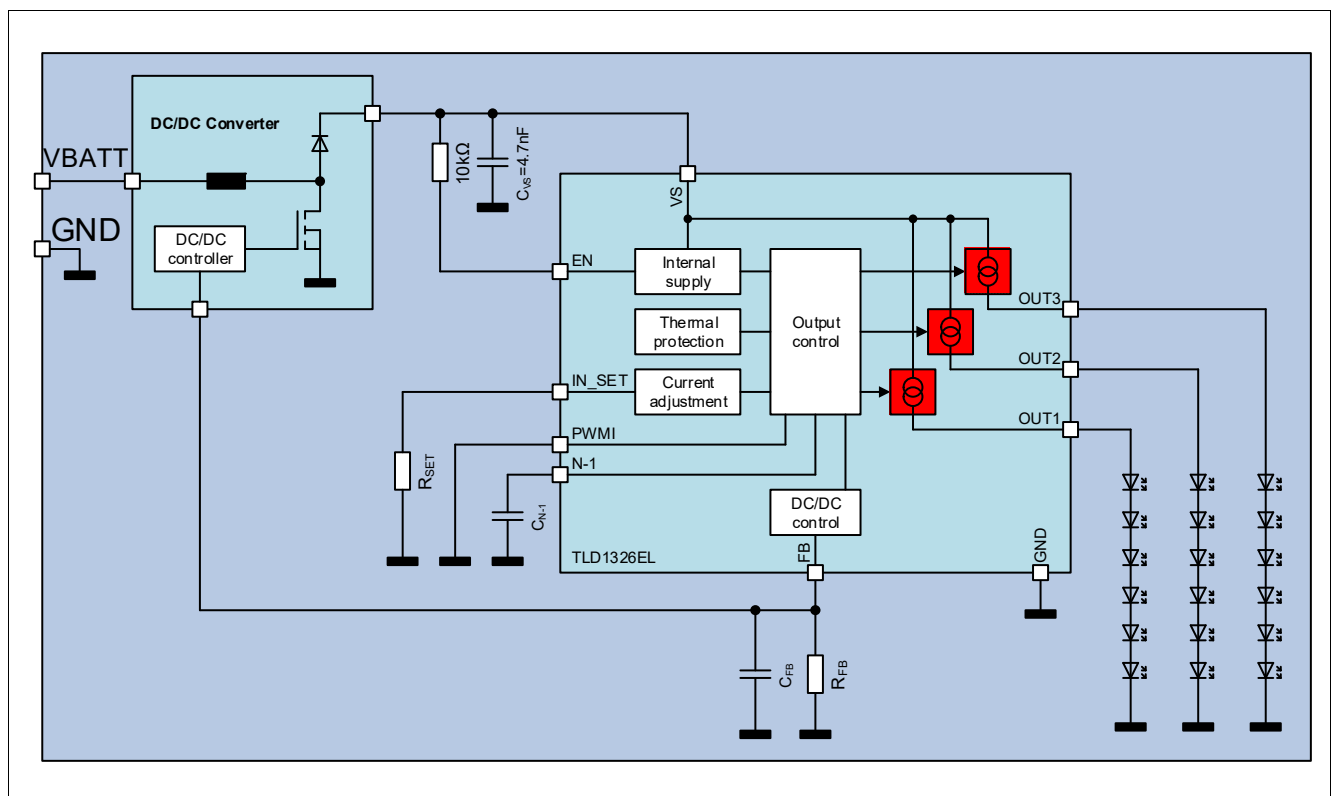

Application Diagram with TLD1326EL

## Overview

### Basic Features

- 3 Channel device with integrated output stages (current sources), optimized to drive LEDs with output current up to 120 mA per channel
- Low current consumption in sleep mode
- PWM-operation supported via VS- and EN-pin
- Integrated PWM dimming engine to provide two LED brightness levels without external logic (e.g.  $\mu\text{C}$ )
- Output current adjustable via external low power resistor and possibility to connect PTC resistor for LED protection during over temperature conditions
- Dynamic overhead control
- Reverse polarity protection and overload protection
- Undervoltage detection
- N-1 detection, latched function
- Wide temperature range:  $-40^\circ\text{C} < T_j < 150^\circ\text{C}$
- PG-SSOP-14 package with exposed heatslug

### Description

The LITIX™ Basic TLD1326EL is a three channel high side driver IC with integrated output stages. It is designed to control LEDs with a current up to 120 mA. In typical automotive applications the device is capable to drive i.e. 3 red LEDs per chain (total 9 LEDs) with a current up to 60 mA, which is limited by thermal cooling aspects. The output current is controlled practically independent of load and supply voltage changes.

**Table 1 Product Summary**

Parameter	Symbol	Value
Operating voltage range	$V_{S(\text{nom})}$	5.5 V ... 40 V
Maximum voltage	$V_{S(\text{max})}$ $V_{\text{OUTx}(\text{max})}$	40 V
Nominal output (load) current	$I_{\text{OUTx}(\text{nom})}$	60 mA when using a supply voltage range of 8 V - 18 V (e.g. Automotive car battery). Currents up to $I_{\text{OUT}(\text{max})}$ possible in applications with low thermal resistance $R_{\text{thJA}}$
Maximum output (load) current	$I_{\text{OUTx}(\text{max})}$	120 mA; depending on thermal resistance $R_{\text{thJA}}$
Output current accuracy at $R_{\text{SET}} = 12 \text{ k}\Omega$	$k_{\text{LT}}$	$750 \pm 7\%$
Current consumption in sleep mode	$I_{S(\text{sleep,typ})}$	0.1 $\mu\text{A}$

### Protective Functions

- ESD protection
- Under voltage lock out
- Over Load protection
- Over Temperature protection
- Reverse Polarity protection

### Diagnostic Functions

- N-1 detection, latched function
- SC to Vs (indicated by N-1 diagnosis)

Block Diagram

## 2 Block Diagram

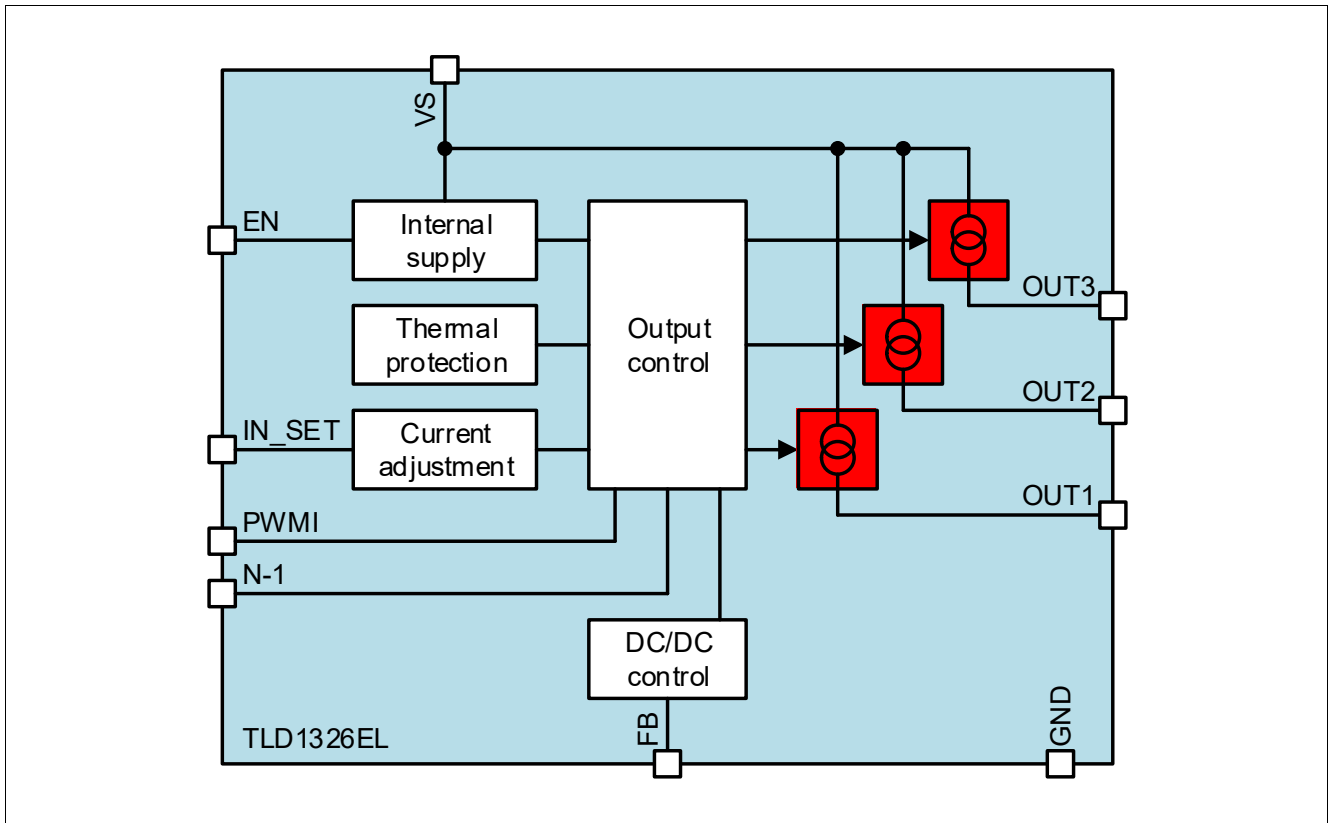

Figure 1 Basic Block Diagram

Pin Configuration

### 3 Pin Configuration

#### 3.1 Pin Assignment

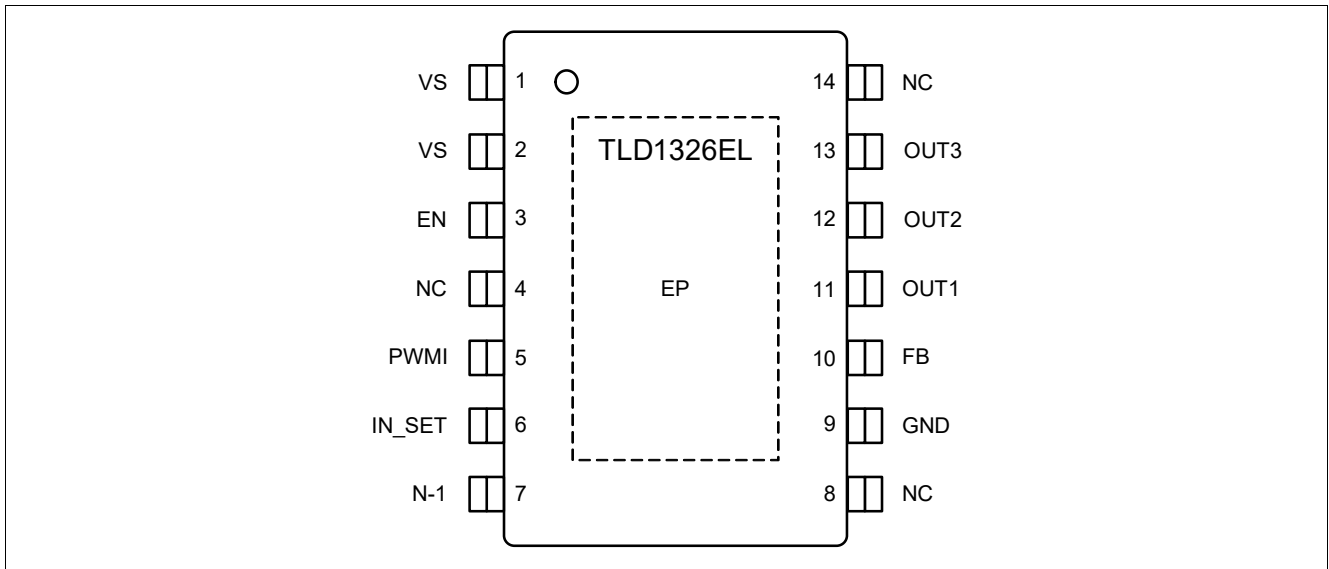

Figure 2 Pin Configuration

Pin Configuration

3.2 Pin Definitions and Functions

Pin	Symbol	Input/ Output	Function
1, 2	VS	–	<b>Supply Voltage;</b> battery supply, connect a decoupling capacitor (100 nF - 1 μF) to GND
3	EN	I	<b>Enable pin</b>
4	NC	–	<b>Pin not connected</b>
5	PWMI	I/O	<b>PWM Input</b>
6	IN_SET	I/O	<b>Input / SET pin;</b> Connect a low power resistor to adjust the output current
7	N-1	I/O	<b>N-1 pin</b>
8	NC	–	<b>Pin not connected</b>
9	GND	–	<sup>1)</sup> <b>Ground</b>
10	FB	O	<b>Feedback Output</b>
11	OUT1	O	<b>Output 1</b>
12	OUT2	O	<b>Output 2</b>
13	OUT3	O	<b>Output 3</b>
14	NC	–	<b>Pin not connected</b>
Exposed Pad	GND	–	<sup>1)</sup> <b>Exposed Pad;</b> connect to GND in application

1) Connect all GND-pins together.

General Product Characteristics

## 4 General Product Characteristics

### 4.1 Absolute Maximum Ratings

#### Absolute Maximum Ratings <sup>1)</sup>

$T_j = -40^{\circ}\text{C}$  to  $+150^{\circ}\text{C}$ ; all voltages with respect to ground, positive current flowing into pin for input pins (I), positive currents flowing out of the I/O and output pins (O) (unless otherwise specified)

Pos.	Parameter	Symbol	Limit Values		Unit	Conditions
			Min.	Max.		
<b>Voltages</b>						
4.1.1	Supply voltage	$V_S$	-16	40	V	-
4.1.2	Input voltage EN	$V_{EN}$	-16	40	V	-
4.1.3	Input voltage EN related to $V_S$	$V_{EN(VS)}$	$V_S - 40$	$V_S + 16$	V	-
4.1.4	Input voltage EN related to $V_{OUTx}$	$V_{EN} - V_{OUTx}$	-16	40	V	-
4.1.5	Output voltage	$V_{OUTx}$	-1	40	V	-
4.1.6	Power stage voltage	$V_{PS}$	-16	40	V	-
	$V_{PS} = V_S - V_{OUTx}$					
4.1.7	Input voltage PWMI	$V_{PWMI}$	-0.3	6	V	-
4.1.8	IN_SET voltage	$V_{IN\_SET}$	-0.3	6	V	-
4.1.9	N-1 voltage	$V_{N-1}$	-0.3	6	V	-
4.1.10	Feedback voltage	$V_{FB}$	-0.3	40	V	-
<b>Currents</b>						
4.1.11	IN_SET current	$I_{IN\_SET}$	-	2 8	mA	- Diagnosis output
4.1.12	N-1 current	$I_{N-1}$	-0.5	0.5	mA	-
4.1.13	Feedback current	$I_{FB}$	-	0.5	mA	-
4.1.14	Output current	$I_{OUTx}$	-	130	mA	-
<b>Temperatures</b>						
4.1.15	Junction temperature	$T_j$	-40	150	$^{\circ}\text{C}$	-
4.1.16	Storage temperature	$T_{stg}$	-55	150	$^{\circ}\text{C}$	-
<b>ESD Susceptibility</b>						
4.1.17	ESD resistivity to GND	$V_{ESD}$	-2	2	kV	Human Body Model (100 pF via 1.5 k $\Omega$ ) <sup>2)</sup>
4.1.18	ESD resistivity all pins to GND	$V_{ESD}$	-500	500	V	CDM <sup>3)</sup>
4.1.19	ESD resistivity corner pins to GND	$V_{ESD}$	-750	750	V	CDM <sup>3)</sup>

1) Not subject to production test, specified by design

2) ESD susceptibility, Human Body Model "HBM" according to ANSI/ESDA/JEDEC JS-001-2011

3) ESD susceptibility, Charged Device Model "CDM" according to JESD22-C101E

*Note: Stresses above the ones listed here may cause permanent damage to the device. Exposure to absolute maximum rating conditions for extended periods may affect device reliability.*

## General Product Characteristics

Note: Integrated protection functions are designed to prevent IC destruction under fault conditions described in the data sheet. Fault conditions are considered as “outside” normal operating range. Protection functions are not designed for continuous repetitive operation.

### 4.2 Functional Range

Pos.	Parameter	Symbol	Limit Values		Unit	Conditions
			Min.	Max.		
4.2.20	Supply voltage range for normal operation	$V_{S(nom)}$	5.5	40	V	–
4.2.21	Power on reset threshold	$V_{S(POR)}$	–	5	V	$V_{EN} = V_S$ $R_{SET} = 12\text{ k}\Omega$ $I_{OUTx} = 80\% I_{OUTx(nom)}$ $V_{OUTx} = 2.5\text{ V}$
4.2.22	Junction temperature	$T_j$	-40	150	°C	–

Note: Within the functional range the IC operates as described in the circuit description. The electrical characteristics are specified within the conditions given in the related electrical characteristics table.

### 4.3 Thermal Resistance

Pos.	Parameter	Symbol	Limit Values			Unit	Conditions
			Min.	Typ.	Max.		
4.3.1	Junction to Case	$R_{thJC}$	–	8	10	K/W	1) 2)
4.3.2	Junction to Ambient 1s0p board	$R_{thJA1}$	–	61	–	K/W	1) 3) $T_a = 85\text{ °C}$ $T_a = 135\text{ °C}$
			–	56	–		
4.3.3	Junction to Ambient 2s2p board	$R_{thJA2}$	–	45	–	K/W	1) 4) $T_a = 85\text{ °C}$ $T_a = 135\text{ °C}$
			–	43	–		

- 1) Not subject to production test, specified by design. Based on simulation results.
- 2) Specified  $R_{thJC}$  value is simulated at natural convection on a cold plate setup (all pins and the exposed Pad are fixed to ambient temperature).  $T_a = 85\text{ °C}$ , Total power dissipation 1.5 W.
- 3) The  $R_{thJA}$  values are according to Jedec JESD51-3 at natural convection on 1s0p FR4 board. The product (chip + package) was simulated on a 76.2 x 114.3 x 1.5 mm<sup>3</sup> board with 70 μm Cu, 300 mm<sup>2</sup> cooling area. Total power dissipation 1.5 W distributed statically and homogeneously over all power stages.
- 4) The  $R_{thJA}$  values are according to Jedec JESD51-5,-7 at natural convection on 2s2p FR4 board. The product (chip + package) was simulated on a 76.2 x 114.3 x 1.5 mm<sup>3</sup> board with 2 inner copper layers (outside 2 x 70 μm Cu, inner 2 x 35 μm Cu). Where applicable, a thermal via array under the exposed pad contacted the first inner copper layer. Total power dissipation 1.5 W distributed statically and homogeneously over all power stages.

EN Pin

## 5 EN Pin

The EN pin is a dual function pin:

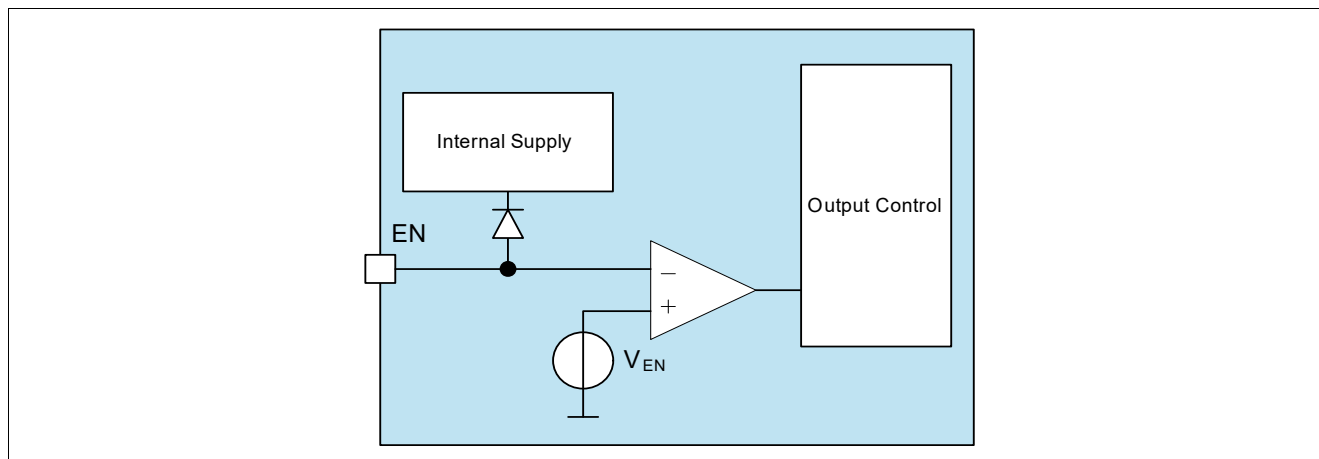
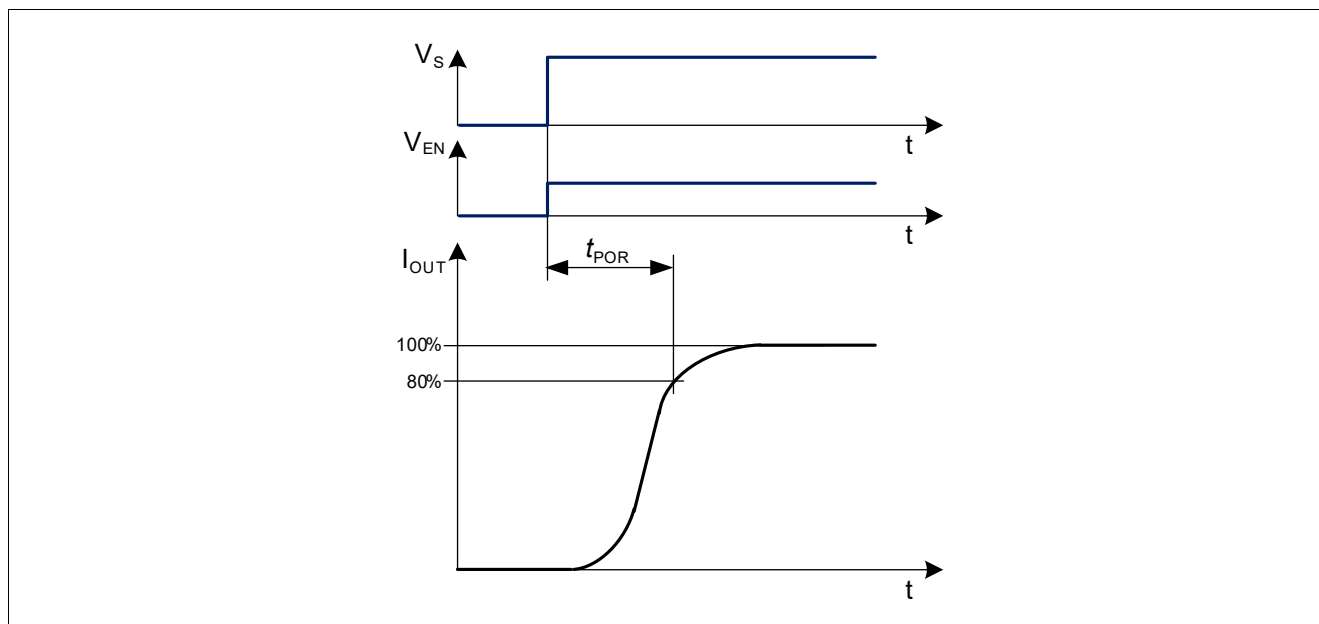

**Figure 3** Block Diagram EN pin

Note: The current consumption at the EN-pin  $I_{EN}$  needs to be added to the total device current consumption. The total current consumption is the sum of the currents at the VS-pin  $I_S$  and the EN-pin  $I_{EN}$ .

### 5.1 EN Function

If the voltage at the pin EN is below a threshold of  $V_{EN(off)}$  the LITIX™ Basic IC will enter Sleep mode. In this state all internal functions are switched off, the current consumption is reduced to  $I_{S(sleep)}$ . A voltage above  $V_{EN(on)}$  at this pin enables the device after the Power on reset time  $t_{POR}$ .



**Figure 4** Power on reset



EN Pin

5.2 Internal Supply Pin

The EN pin can be used to supply the internal logic. There are two typical application conditions, where this feature can be used:

- 1) In “DC/DC control Buck” configurations, where the voltage  $V_s$  can be below 5.5V (see [Figure 20](#) for details).
- 2) In configurations, where a PWM signal is applied at the Vbatt pin of a light module. The buffer capacitor  $C_{BUF}$  is used to supply the LITIX™ Basic IC during Vbatt low ( $V_s$  low) periods. This feature can be used to minimize the turn-on time to the values specified in [Pos. 10.2.13](#). Otherwise, the power-on reset delay time  $t_{POR}$  ([Pos. 6.3.6](#)) has to be considered.

The capacitor can be calculated using the following formula:

$$C_{BUF} = t_{LOW(max)} \cdot \frac{I_{EN(LS)}}{V_s - V_{D1} - V_{S(POR)}} \tag{1}$$

See also a typical application drawing in [Chapter 11](#).

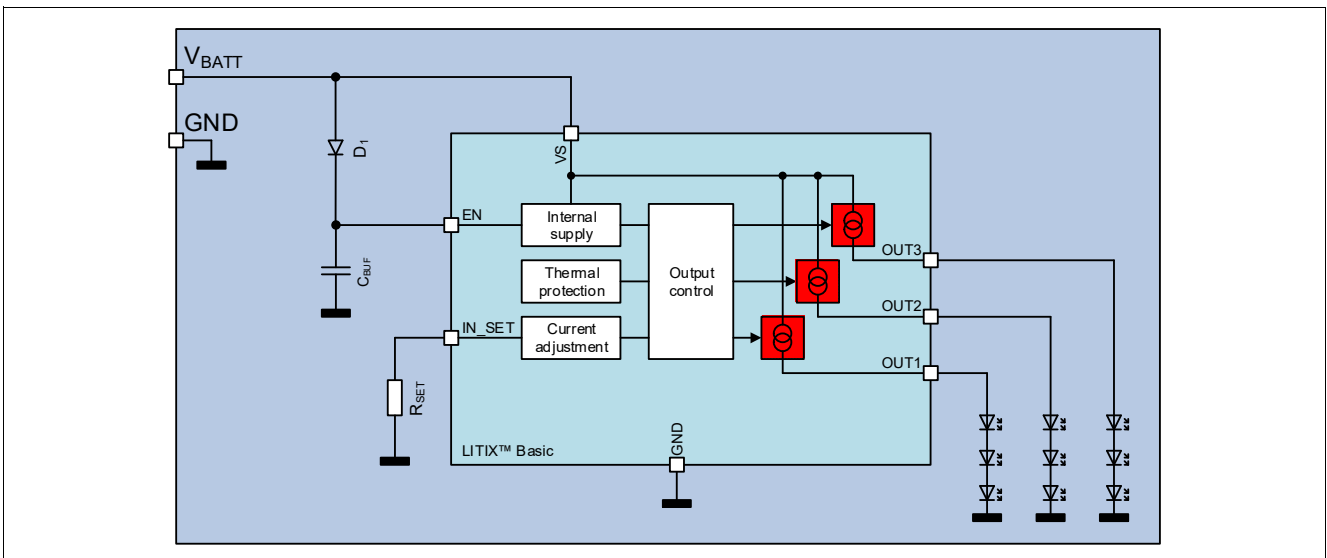
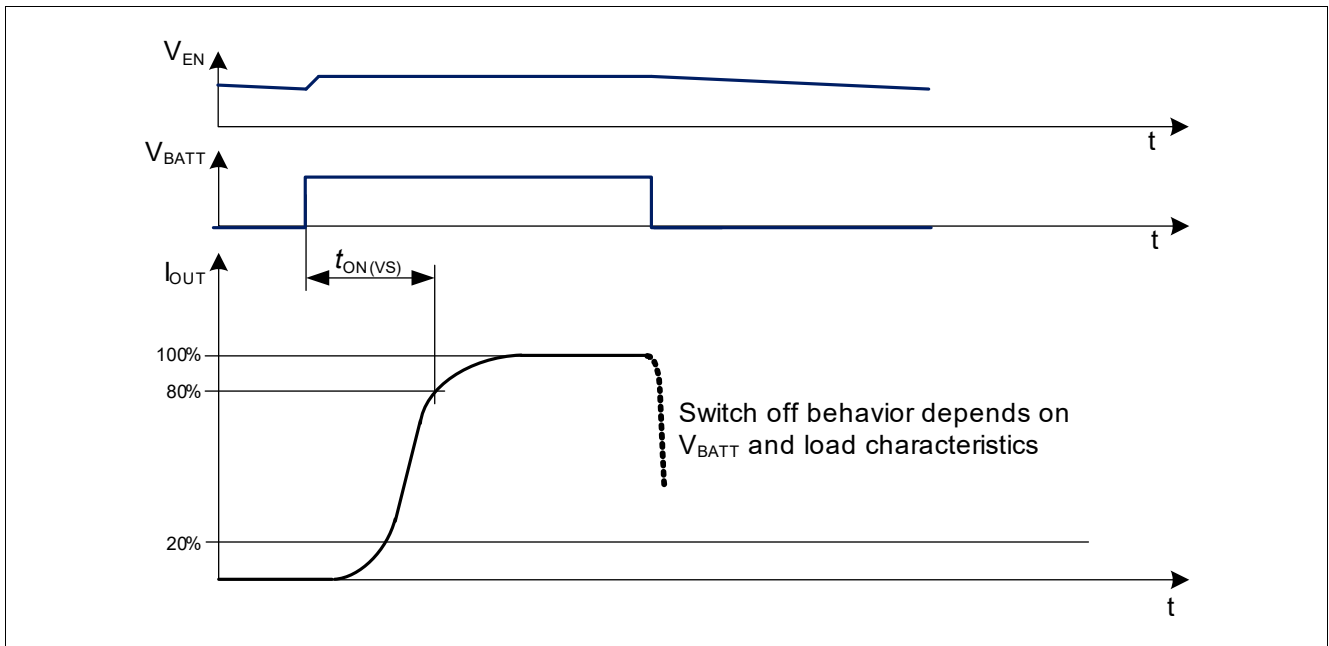

Figure 5 External circuit when applying a fast PWM signal on V<sub>BATT</sub>

EN Pin



**Figure 6** Typical waveforms when applying a fast PWM signal on  $V_{BATT}$

The parameter  $t_{ON(VS)}$  is defined at [Pos. 10.2.13](#). The parameter  $t_{OFF(VS)}$  depends on the load and supply voltage  $V_{BATT}$  characteristics.

### 5.3 EN Unused

In case of an unused EN pin, there are two different ways to connect it:

#### 5.3.1 EN - Pull Up to VS

The EN pin can be connected with a pull up resistor (e.g. 10 k $\Omega$ ) to  $V_s$  potential. In this configuration the LITIX™ Basic IC is always enabled.

#### 5.3.2 EN - Direct Connection to VS

The EN pin can be connected directly to the VS pin (IC always enabled). This configuration has the advantage (compared to the configuration described in [Chapter 5.3.1](#)) that no additional external component is required.

PWMI Pin

## 6 PWMI Pin

The PWMI pin is designed as a dual function pin.

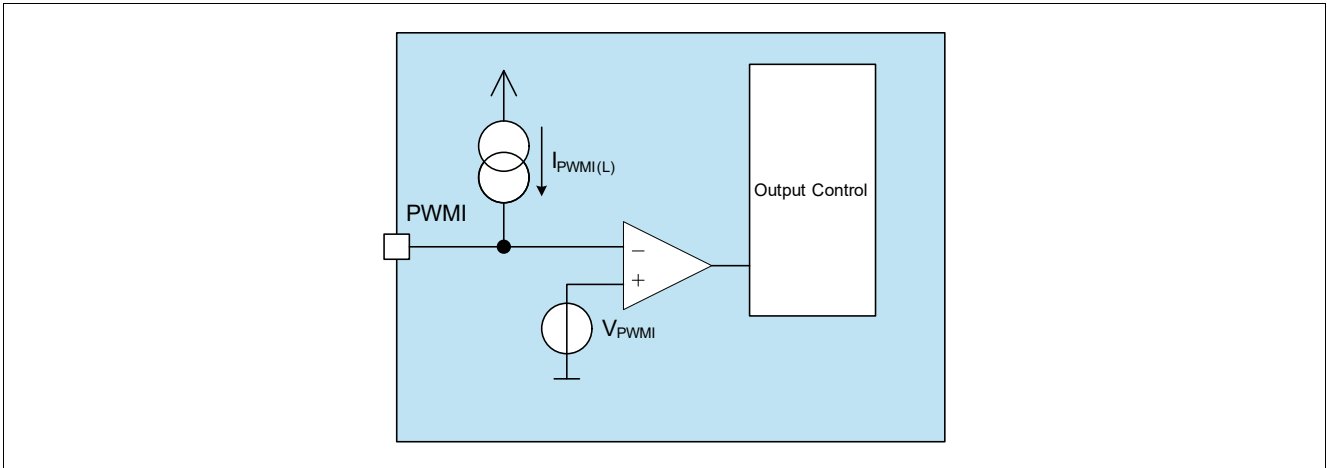

**Figure 7 Block Diagram PWMI pin**

The pin can be used for PWM-dimming via a push-pull stage of a micro controller, which is connecting the PWMI-pin to a low or high potential.

*Note: The micro controller's push-pull stage has to be able to sink currents according to [Pos. 6.3.16](#) to activate the device.*

Furthermore, the device offers also an internal PWM unit by connecting an external-RC network according to [Figure 10](#).

### 6.1 PWM Dimming

A PWM signal can be applied at the PWMI pin for LED brightness regulation. The dimming frequency can be adjusted in a very wide range (e.g. 400 Hz). The PWMI pin is low active. Turn on/off thresholds  $V_{PWM(L)}$  and  $V_{PWM(H)}$  are specified in parameters [Pos. 6.3.13](#) and [Pos. 6.3.14](#).

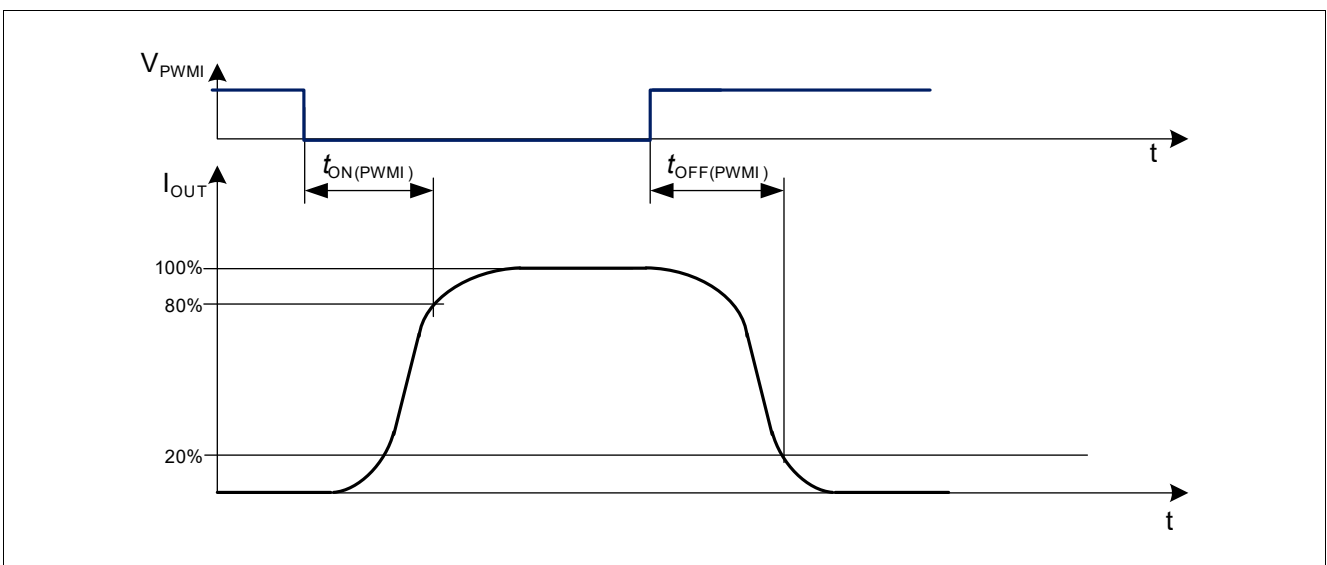
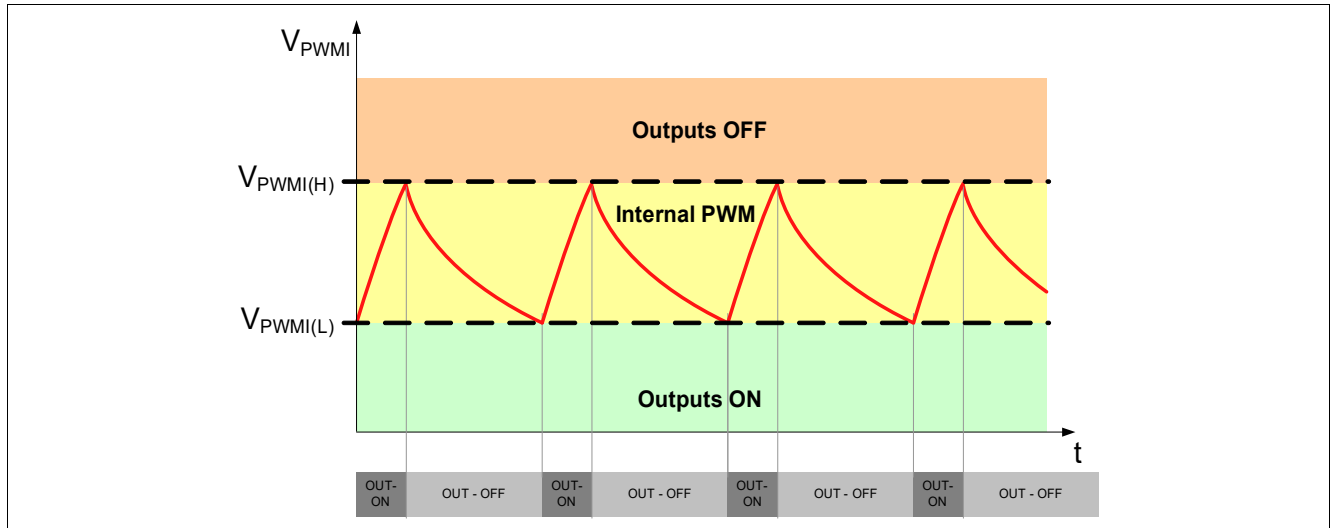

**Figure 8 Turn on and Turn off time for PWMI pin usage**

PWMI Pin

### 6.2 Internal PWM Unit

Connecting a resistor and a capacitor in parallel on the PWMI pin enables the internal pulse width modulation unit. The following figure shows the charging and discharging defined by the RC-network according to and the internal PWM unit.



**Figure 9 PWMI operating voltages**

The PWM Duty cycle (DC) and the PWM frequency can be adjusted using the formulas below. Please use only typical values of  $V_{PWMI(L)}$ ,  $V_{PWMI(H)}$  and  $I_{PWMI(on)}$  for the calculation of  $t_{PWMI(on)}$  and  $t_{PWMI(off)}$  (as described in **Pos. 6.3.13** to **Pos. 6.3.16**).

$$t_{PWMI(on)} = -R_{PWMI} \cdot C_{PWMI} \cdot \text{LN} \left( \frac{V_{PWMI(H)} - I_{PWMI(on)} \cdot R_{PWMI}}{V_{PWMI(L)} - I_{PWMI(on)} \cdot R_{PWMI}} \right) \quad (2)$$

$$t_{PWMI(off)} = R_{PWMI} \cdot C_{PWMI} \cdot \text{LN} \left( \frac{V_{PWMI(H)}}{V_{PWMI(L)}} \right) \quad (3)$$

$$f_{PWMI} = \frac{1}{t_{PWMI(on)} + t_{PWMI(off)}} \quad (4)$$

$$DC = t_{PWMI(on)} \cdot f_{PWMI} \quad (5)$$

Out of this equations the required  $C_{PWMI}$  and  $R_{PWMI}$  can be calculated:

$$C_{PWMI} = \frac{-I_{PWMI(on)} \cdot t_{PWMI(off)} \cdot \left[ \left( \frac{V_{PWMI(L)}}{V_{PWMI(H)}} \right)^{t_{PWMI(off)}} - 1 \right]}{\text{LN} \left( \frac{V_{PWMI(L)}}{V_{PWMI(H)}} \right) \cdot \left[ V_{PWMI(L)} \cdot \left( \frac{V_{PWMI(L)}}{V_{PWMI(H)}} \right)^{t_{PWMI(off)}} - V_{PWMI(H)} \right]} \quad (6)$$

$$R_{PWMI} = \frac{t_{PWMI(off)}}{C_{PWMI} \cdot \text{LN} \left( \frac{V_{PWMI(H)}}{V_{PWMI(L)}} \right)} \quad (7)$$

See **Figure 10** for a typical external circuitry.

PWMI Pin

Note: In case of junction temperatures above  $T_{j(CRT)}$  (Pos. 10.2.14) the device provides a temperature dependent current reduction feature as described in Chapter 10.1.1. In case of output current reduction  $I_{IN\_SET}$  is reduced as well, which leads to increased turn on-times  $t_{PWMI(on)}$ , because the  $C_{PWMI}$  is charged slower. The turn off-time  $t_{PWMI(off)}$  remains the same.

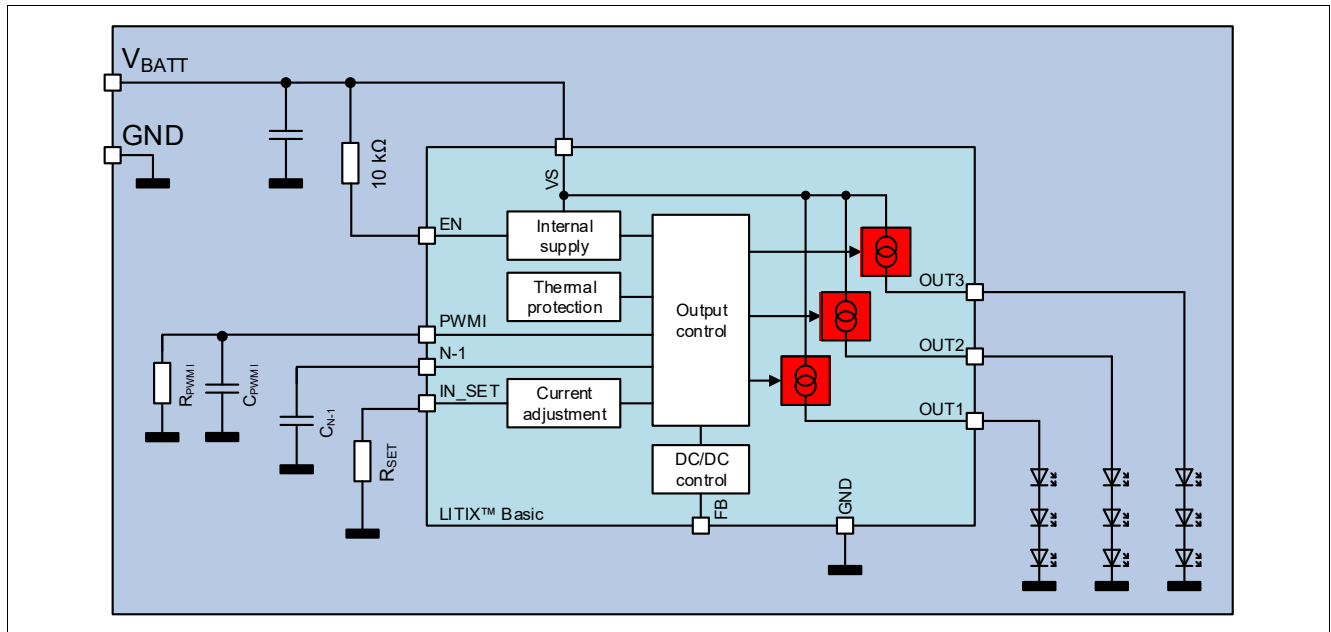

Figure 10 Typical circuit using internal PWM unit

### 6.3 Electrical Characteristics Internal Supply / EN / PWMI Pin

#### Electrical Characteristics Internal Supply / EN / PWMI pin

Unless otherwise specified:  $V_S = 5.5 \text{ V to } 40 \text{ V}$ ,  $T_j = -40^\circ\text{C to } +150^\circ\text{C}$ ,  $R_{SET} = 12 \text{ k}\Omega$  all voltages with respect to ground, positive current flowing into pin for input pins (I), positive currents flowing out of the I/O and output pins (O) (unless otherwise specified)

Pos.	Parameter	Symbol	Limit Values			Unit	Conditions
			Min.	Typ.	Max.		
6.3.1	Current consumption, sleep mode	$I_{S(sleep)}$	-	0.1	2	$\mu\text{A}$	<sup>1)</sup> $V_{EN} = 0.5 \text{ V}$ $T_j < 85^\circ\text{C}$ $V_S = 18 \text{ V}$ $V_{OUTx} = 3.6 \text{ V}$
6.3.2	Current consumption, active mode	$I_{S(on)}$	-	-	1.7	mA	<sup>2)</sup> $V_{PWMI} = 0.5 \text{ V}$ $I_{IN\_SET} = 0 \mu\text{A}$ $T_j < 105^\circ\text{C}$ $V_S = 18 \text{ V}$ $V_{OUTx} = 3.6 \text{ V}$ $V_{EN} = 5.5 \text{ V}$ $V_{EN} = 18 \text{ V}$ <sup>1)</sup> $R_{EN} = 10 \text{ k}\Omega$ between VS and EN-pin
			-	-	1.0		
			-	-	1.75		
			-	-	-		

PWMI Pin

Electrical Characteristics Internal Supply / EN / PWMI pin (cont'd)

Unless otherwise specified:  $V_S = 5.5\text{ V to }40\text{ V}$ ,  $T_j = -40^\circ\text{C to }+150^\circ\text{C}$ ,  $R_{SET} = 12\text{ k}\Omega$  all voltages with respect to ground, positive current flowing into pin for input pins (I), positive currents flowing out of the I/O and output pins (O) (unless otherwise specified)

Pos.	Parameter	Symbol	Limit Values			Unit	Conditions
			Min.	Typ.	Max.		
6.3.3	Current consumption, device disabled via IN_SET	$I_{S(dis,IN\_SET)}$	-	-	1.65 0.9 1.7	mA	<sup>2)</sup> $V_S = 18\text{ V}$ $T_j < 105^\circ\text{C}$ $V_{IN\_SET} = 5\text{ V}$ $V_{EN} = 5.5\text{ V}$ $V_{EN} = 18\text{ V}$ <sup>1)</sup> $R_{EN} = 10\text{ k}\Omega$ between VS and EN-pin
6.3.4	Current consumption, device disabled via PWMI	$I_{S(dis,PWMI)}$	-	-	1.9 1.0 2.0	mA	<sup>2)</sup> $V_S = 18\text{ V}$ $T_j < 105^\circ\text{C}$ $V_{PWMI} = 3.4\text{ V}$ $V_{EN} = 5.5\text{ V}$ $V_{EN} = 18\text{ V}$ <sup>1)</sup> $R_{EN} = 10\text{ k}\Omega$ between VS and EN-pin
6.3.5	Current consumption, active mode in single fault detection condition	$I_{S(fault)}$	-	-	6.0 4.9 5.9	mA	<sup>2)</sup> $V_S = 18\text{ V}$ $T_j < 105^\circ\text{C}$ $R_{SET} = 12\text{ k}\Omega$ $V_{PWMI} = 0.5\text{ V}$ $V_{OUTx} = 18\text{ V}$ $V_{EN} = 5.5\text{ V}$ $V_{EN} = 18\text{ V}$ <sup>1)</sup> $R_{EN} = 10\text{ k}\Omega$ between VS and EN-pin
6.3.6	Power-on reset delay time <sup>3)</sup>	$t_{POR}$	-	-	25	$\mu\text{s}$	<sup>1)</sup> $V_S = V_{EN} = 0 \rightarrow 13.5\text{ V}$ $V_{OUTx(nom)} = 3.6 \pm 0.3\text{ V}$ $I_{OUTx} = 80\% I_{OUTx(nom)}$
6.3.7	Required supply voltage for output activation	$V_{S(on)}$	-	-	4	V	$V_{EN} = 5.5\text{ V}$ $V_{OUTx} = 3\text{ V}$ $I_{OUTx} = 50\% I_{OUTx(nom)}$
6.3.8	Required supply voltage for current control	$V_{S(CC)}$	-	-	5.2	V	$V_{EN} = 5.5\text{ V}$ $V_{OUTx} = 3.6\text{ V}$ $I_{OUTx} \geq 90\% I_{OUTx(nom)}$
6.3.9	EN turn on threshold	$V_{EN(on)}$	-	-	2.5	V	-
6.3.10	EN turn off threshold	$V_{EN(off)}$	0.8	-	-	V	-
6.3.11	EN input current during low supply voltage	$I_{EN(LS)}$	-	-	1.8	mA	<sup>1)</sup> $V_S = 4.5\text{ V}$ $T_j < 105^\circ\text{C}$ $V_{EN} = 5.5\text{ V}$

PWMI Pin

Electrical Characteristics Internal Supply / EN / PWMI pin (cont'd)

Unless otherwise specified:  $V_S = 5.5\text{ V to }40\text{ V}$ ,  $T_j = -40^\circ\text{C to }+150^\circ\text{C}$ ,  $R_{SET} = 12\text{ k}\Omega$  all voltages with respect to ground, positive current flowing into pin for input pins (I), positive currents flowing out of the I/O and output pins (O) (unless otherwise specified)

Pos.	Parameter	Symbol	Limit Values			Unit	Conditions
			Min.	Typ.	Max.		
6.3.12	EN high input current	$I_{EN(H)}$	-	-	0.1	mA	$T_j < 105^\circ\text{C}$ $V_S = 13.5\text{ V}, V_{EN} = 5.5\text{ V}$ $V_S = 18\text{ V}, V_{EN} = 5.5\text{ V}$ $V_S = V_{EN} = 18\text{ V}$ <sup>1)</sup> $V_S = 18\text{ V}, R_{EN} = 10\text{ k}\Omega$ between VS and EN-pin
					0.1		
					1.65		
					0.45		
6.3.13	PWMI (active low) Switching low threshold (outputs on)	$V_{PWMI(L)}$	1.5	1.85	2.3	V	<sup>1)4)</sup> $V_S = 8\dots18\text{ V}$
6.3.14	PWMI(active low) Switching high threshold (outputs off)	$V_{PWMI(H)}$	2.45	2.85	3.2	V	<sup>1)4)5)</sup> $V_S = 8\dots18\text{ V}$
6.3.15	PWMI Switching threshold difference $V_{PWMI(H)} - V_{PWMI(L)}$	$\Delta V_{PWMI}$	0.75	1	1.10	V	<sup>1)4)5)</sup> $V_S = 8\dots18\text{ V}$
6.3.16	PWMI (active low) Low input current with active channels (voltage < $V_{PWMI(L)}$ )	$I_{PWMI(on)}$	$I_{IN\_SET}$ *3.1	$I_{IN\_SET}$ *4	$I_{IN\_SET}$ *4.9	$\mu\text{A}$	<sup>1)</sup> $T_j = 25\dots115^\circ\text{C}$ $I_{IN\_SET} = 100\text{ }\mu\text{A}$ $V_{PWMI} = 1.7\text{ V}$ $V_{EN} = 5.5\text{ V}$ $V_S = 8\dots18\text{ V}$
6.3.17	PWMI(active low) High input current	$I_{PWMI(off)}$	-5	-	5	$\mu\text{A}$	$V_{PWMI} = 5\text{ V}$ $V_{EN} = 5.5\text{ V}$ $V_S = 8\dots18\text{ V}$

- 1) Not subject to production test, specified by design
- 2) The total device current consumption is the sum of the currents  $I_S$  and  $I_{EN(H)}$ , please refer to **Pos. 6.3.12**
- 3) See also **Figure 4**
- 4) Parameter valid if an external PWM signal is applied
- 5) If TTL level compatibility is required, use  $\mu\text{C}$  open drain output with pull up resistor

FB Pin

## 7 FB Pin

The following block diagram shows the feedback pin functionality.

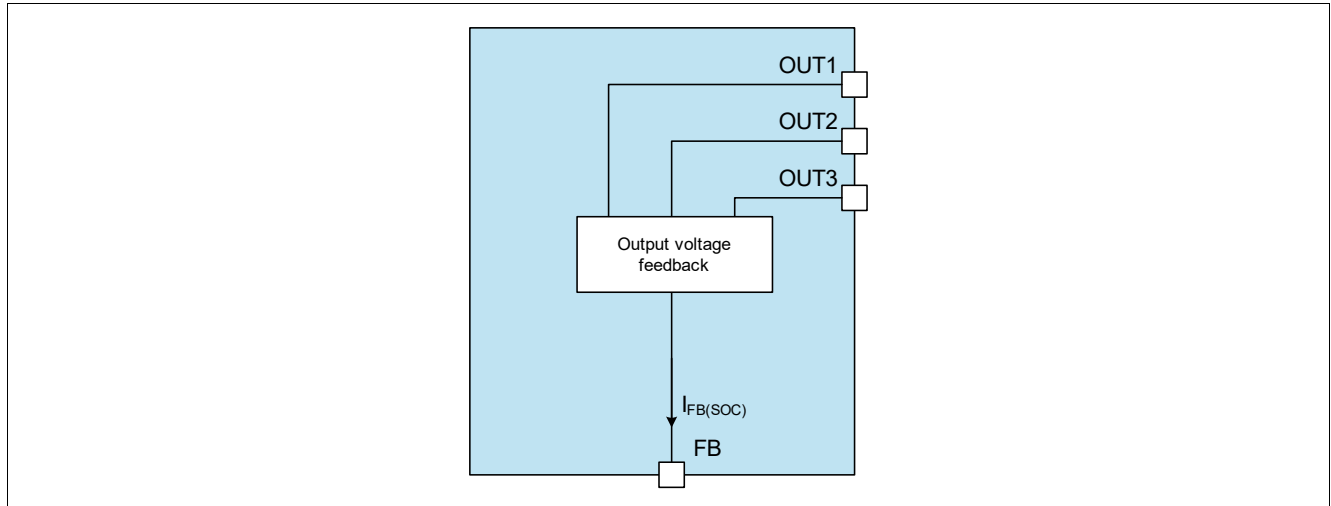

Figure 11 Block Diagram FB pin

### 7.1 DC/DC Control

With the FB pin the LITIX™ Basic IC realizes the dynamic overhead control. The IC provides a voltage feedback to an external DC/DC converter. Using the circuit shown in **Figure 20** it is possible to adjust the DC/DC output voltage in a way that the voltage drop over the output stages of the LITIX™ Basic IC is minimized - dynamic overhead control. This leads to a significant reduction of the overall driver's power dissipation and an increased system efficiency. **Figure 21** shows the same concept but, using a higher number of LEDs per LED chain (please note that the cathode of the LED chain is connected to  $V_{IN}$ ).

*Note: For correct output current control and dynamic overhead control the parameters as specified in **Pos. 7.2.1** and **Pos. 7.2.2** need to be considered. FB source currents higher than given in **Pos. 7.2.1** lead to a drop of the FB regulation voltage  $V_{FB(nom)}$ .*

The resistor  $R_{FB(PD)}$  can be dimensioned by applying equations **Equation (8)** and **Equation (9)**. The following parameters are required:

- $V_{OUT}$  represents the maximum LED loads forward voltage, i.e. number of LEDs multiplied with the maximum LED forward voltage. Temperature drifts of the LED's forward voltage needs to be considered!
- $V_{BO}$  represents the DC/DC output voltage, which is predefined by the feedback resistors (**Figure 20**:  $R_{FB1}$ ,  $R_{FB2}$ ,  $R_{FB3}$  **Figure 21**:  $R_{FB1}$ ,  $R_{FB2}$ ,  $R_{FB3}$ ). Please refer to the according DC/DC device data sheet for the dimensioning of those resistors.
- $n_{len}$  represents the numbers of LITIX™ Basics using the longest LED-chains (e.g. if there are 3 devices connected to one DC/DC converter and two devices using LED chains with 7 LEDs and one device is used with LED chain lengths of 6 LEDs the according  $n_{len} = 2$ .)
- $\beta$  represents the DC gain of the external bipolar transistor, which is connected to the DC/DC's feedback pin.

$$R_{FB(PD,min)} = \min \left\{ \frac{V_{OUT} - 0.5 \text{ V}}{4 \cdot 10^{-5} \text{ A}} \cdot \frac{1}{n_{len}}, \frac{V_{OUT} - 1.1 \text{ V}}{V_{BO} - V_{OUT} - 1.1 \text{ V}} \cdot \frac{1.7 \cdot 10^5 \Omega}{n_{len}} \right\} \quad (8)$$

$$R_{FB(PD,max)} = \frac{V_{OUT} - 1.1 \text{ V}}{V_{BO} - V_{OUT}} \cdot \frac{1}{R_{FB1} \cdot (\beta + 1)} \quad (9)$$



FB Pin

## 7.2 Electrical Characteristics FB Pin

### Electrical Characteristics FB pin

Unless otherwise specified:  $V_S = 5.5\text{ V to }40\text{ V}$ ,  $T_j = -40^\circ\text{C to }+150^\circ\text{C}$ ,  $R_{SET} = 12\text{ k}\Omega$ , all voltages with respect to ground, positive current flowing into pin for input pins (I), positive currents flowing out of the I/O and output pins (O) (unless otherwise specified)

Pos.	Parameter	Symbol	Limit Values			Unit	Conditions
			Min.	Typ.	Max.		
7.2.1	FB regulation voltage	$V_{FB(nom)}$	$(V_{OUT} - 1) * 0.9$	$V_{OUT} - 1$	-	V	$I_{FB(SOC)} = 25\ \mu\text{A}$
7.2.2	FB operating voltage at power stage $V_{PS(FB)} = V_S - V_{OUTx}$	$V_{PS(FB)}$	-	-	10	V	<sup>1)</sup>

1) Not subject to production test, specified by design

IN\_SET Pin

## 8 IN\_SET Pin

The IN\_SET pin is a multiple function pin for output current definition, input and diagnostics:

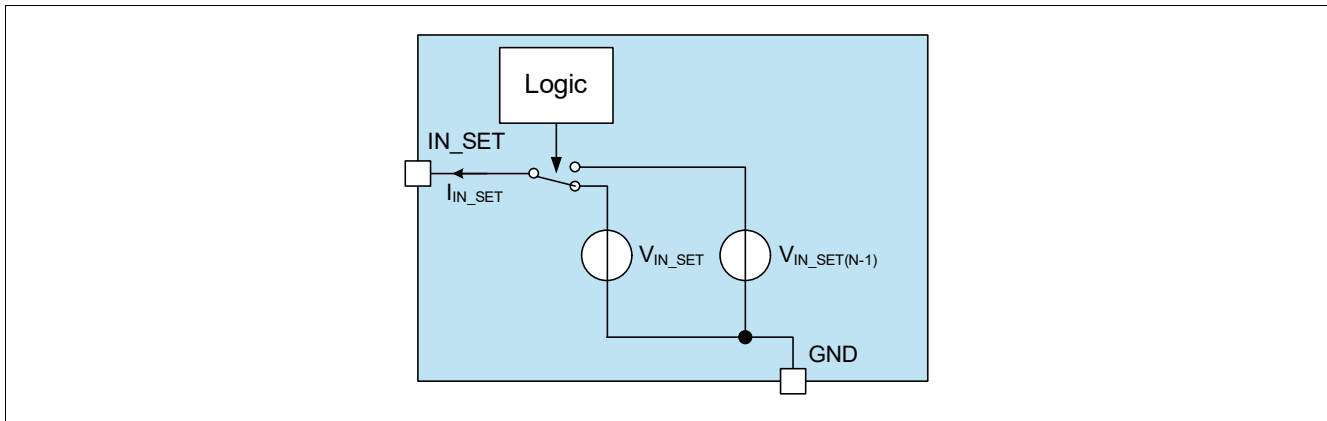

Figure 12 Block Diagram IN\_SET pin

### 8.1 Output Current Adjustment via RSET

The output current for all three channels can only be adjusted simultaneously. The current adjustment can be done by placing a low power resistor ( $R_{SET}$ ) at the IN\_SET pin to ground. The dimensioning of the resistor can be done using the formula below:

$$R_{SET} = \frac{k}{I_{OUT}} \quad (10)$$

The gain factor  $k$  ( $R_{SET} \cdot$  output current) is specified in [Pos. 10.2.4](#) and [Pos. 10.2.5](#). The current through the  $R_{SET}$  is defined by the resistor itself and the reference voltage  $V_{IN\_SET(ref)}$ , which is applied to the IN\_SET during supplied device.

### 8.2 Smart Input Pin

The IN\_SET pin can be connected via  $R_{SET}$  to the open-drain output of a  $\mu C$  or to an external NMOS transistor as described in [Figure 13](#). This signal can be used to turn off the output stages of the IC. A minimum IN\_SET current of  $I_{IN\_SET(act)}$  is required to turn on the output stages. This feature is implemented to prevent glimmering of LEDs caused by leakage currents on the IN\_SET pin, see [Figure 15](#) for details. In addition, the IN\_SET pin offers the diagnostic feedback information. In case of a fault event the IN\_SET voltage is increased to  $V_{IN\_SET(N-1)}$  [Pos. 9.3.2](#). Therefore, the device has two voltage domains at the IN\_SET-pin, which is shown in [Figure 16](#).

IN\_SET Pin

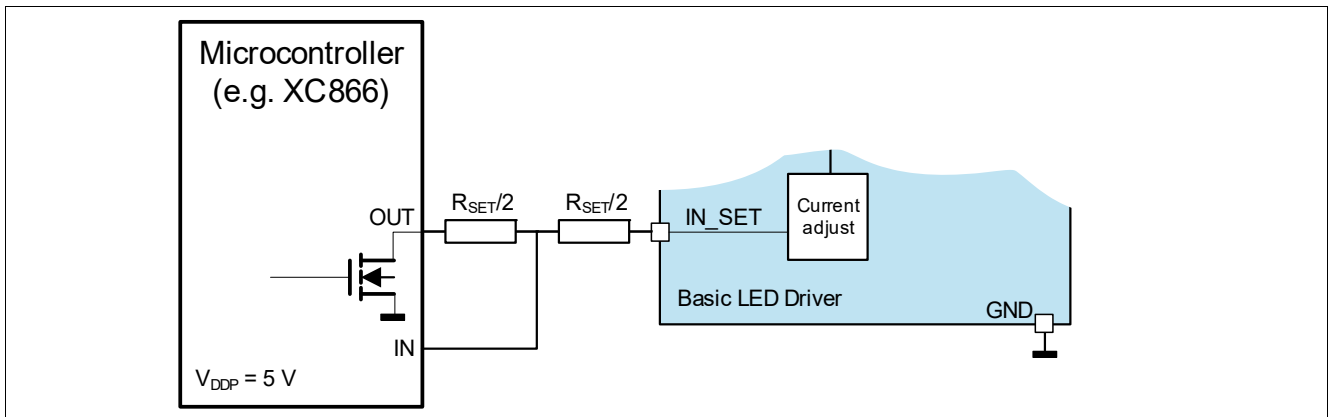

**Figure 13 Schematics IN\_SET interface to  $\mu$ C**

The resulting switching times are shown in [Figure 14](#):

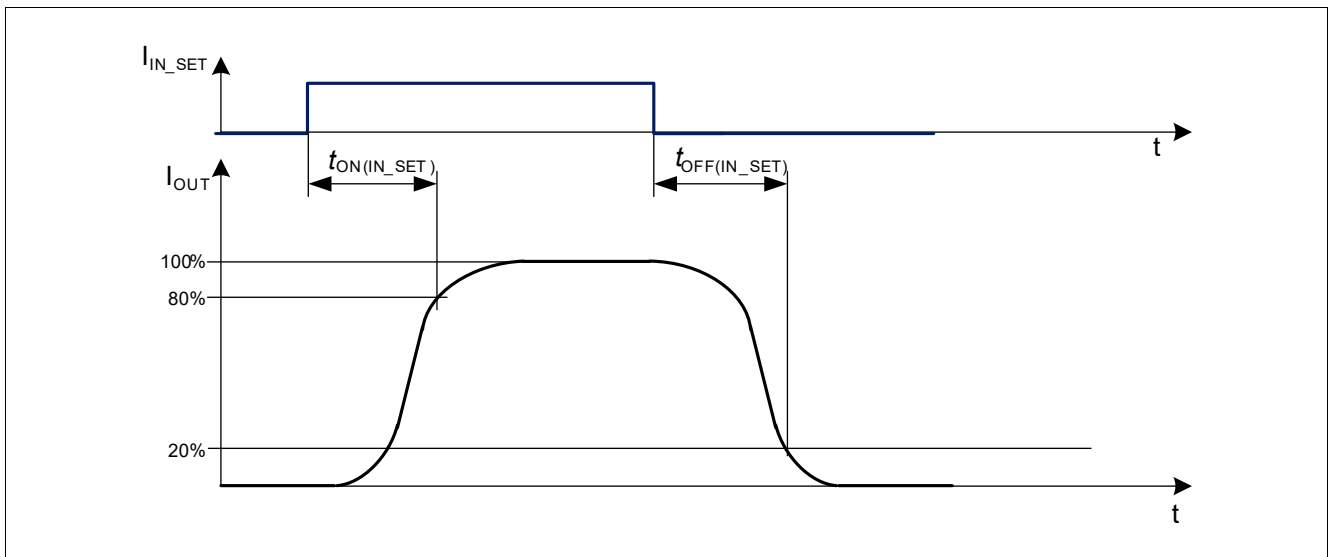

**Figure 14 Switching times via IN\_SET**

IN\_SET Pin

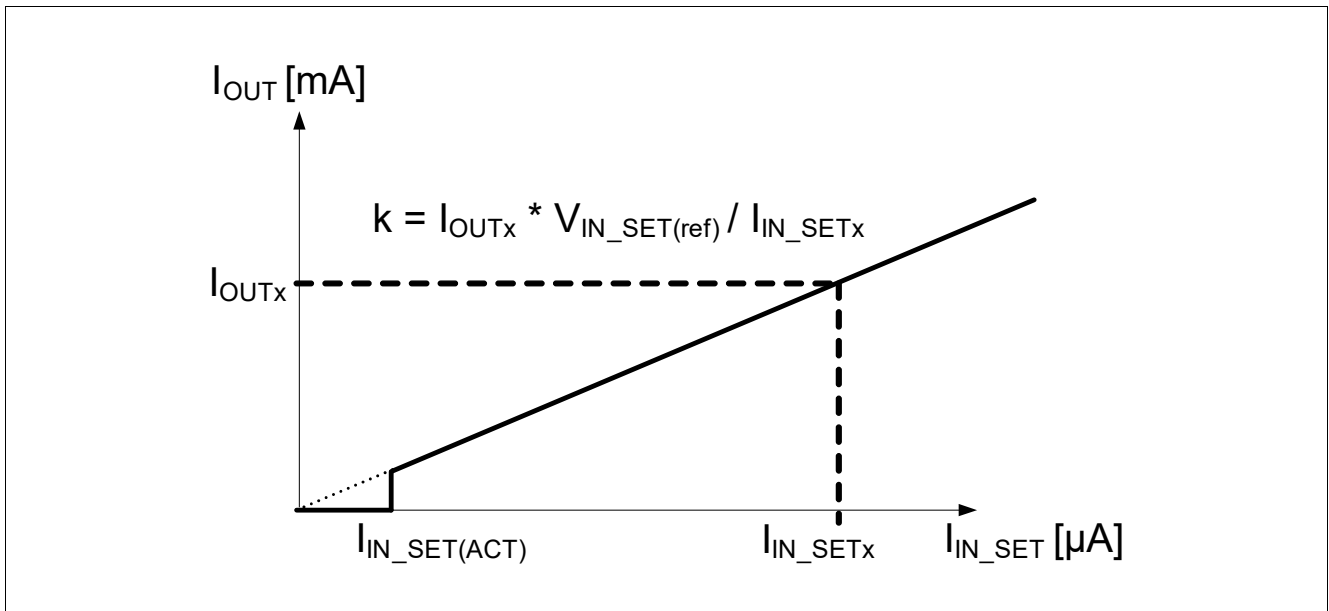

Figure 15  $I_{OUT}$  versus  $I_{INSET}$

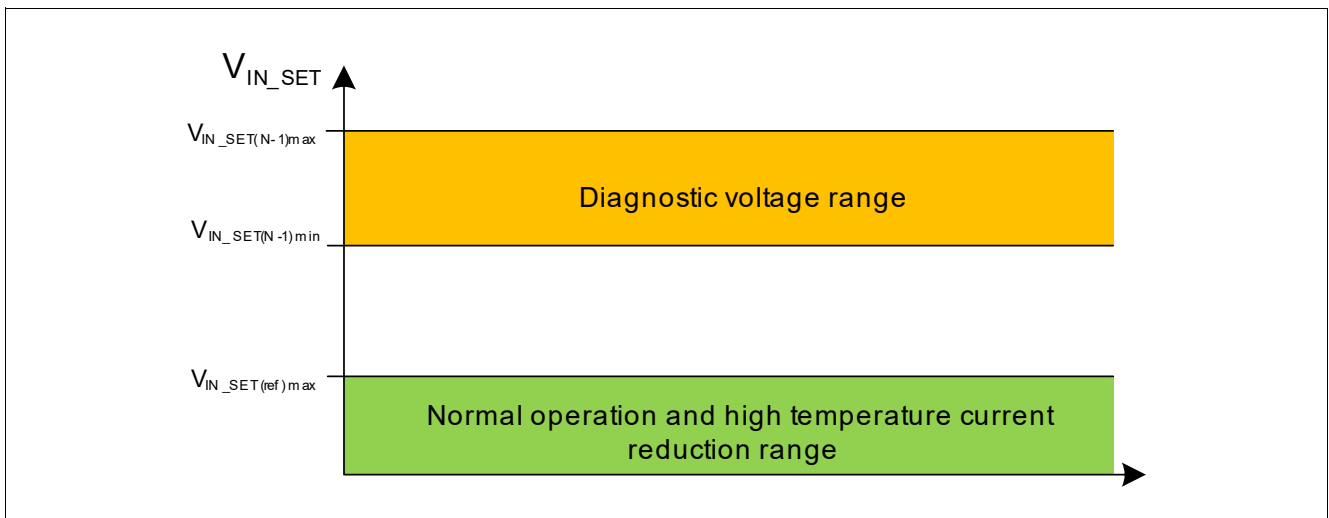

Figure 16 Voltage domains for IN\_SET pin, if ST pin is connected to GND

## 9 Load Diagnosis

### 9.1 N-1 Detection

The N-1 diagnosis is specially designed to detect error conditions in LED arrays with multiple LED chains used for one light function. If one LED within one chain fails in open condition the respective LED chain is off. Different automotive applications require a complete deactivation of a light function, if the desired brightness of the function (LED array) can not be achieved due to an internal error condition. Such a deactivation feature is integrated in the LITIX™ Basic IC.

The functionality of the N-1 pin is shown in the following block diagram:

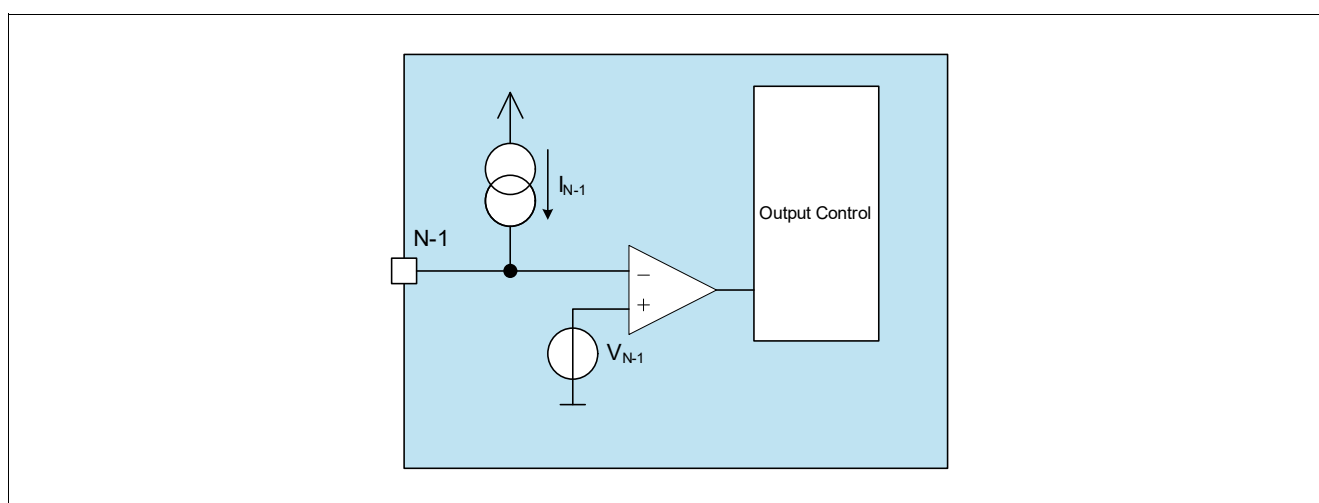
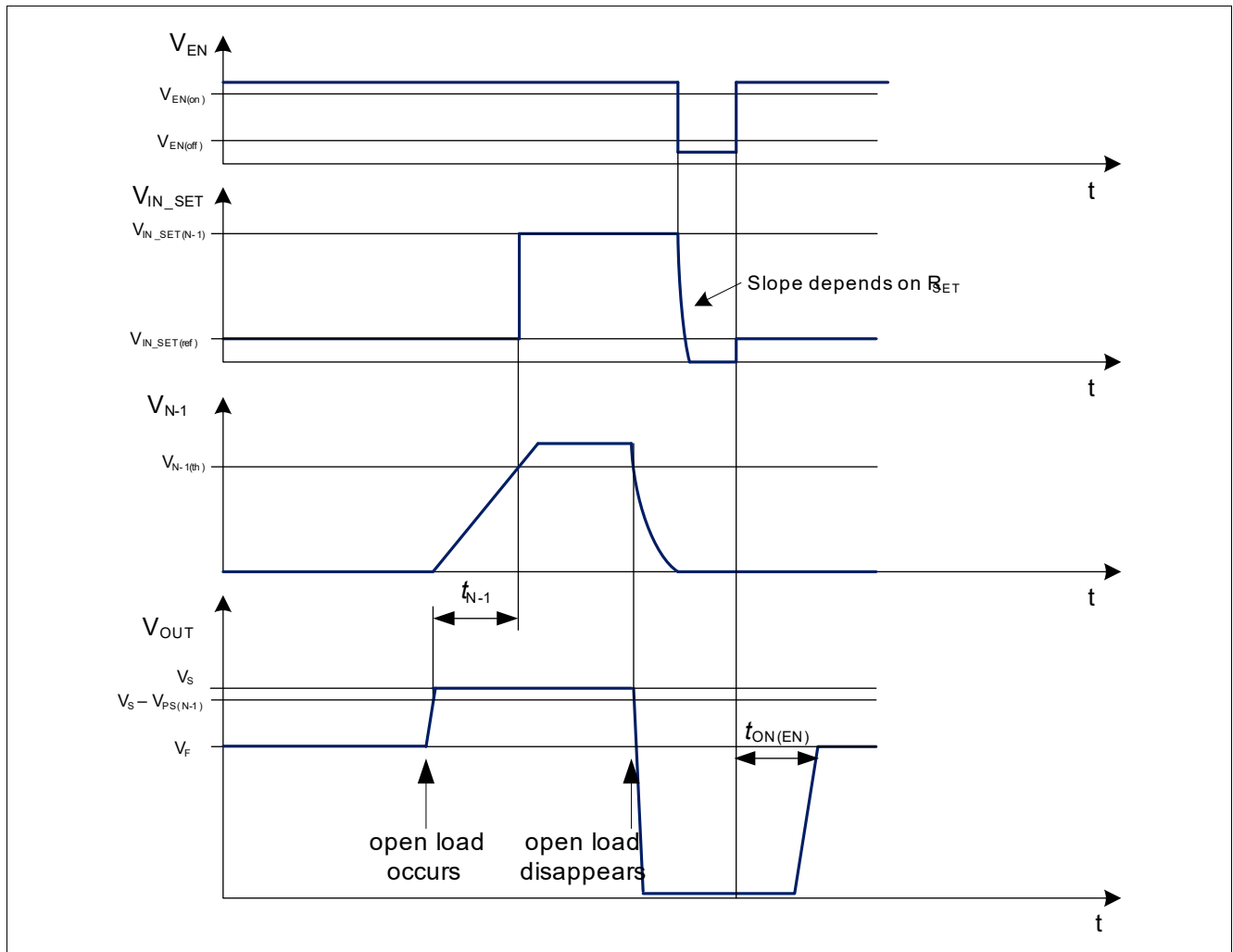

**Figure 17 Block Diagram N-1 pin**

In applications, where more than one LITIX™ Basic IC is used, the IN\_SET pins can be connected via the PWM pins as shown in [Figure 20](#) and [Figure 21](#). This circuit can be used to disable all output stages (of all LITIX™ Basic ICs) during an open load event on one channel. The outputs are deactivated after a N-1 filter time  $t_{N-1}$ , which is defined by the charging current  $I_{N-1}$  ([Pos. 9.3.6](#)). The time is adjustable with a capacitor connected to the N-1 pin according the following equation:

$$t_{\text{typ}} = \frac{C_{N-1} \cdot V_{N-1(\text{th})}}{I_{N-1}} \quad (11)$$

Load Diagnosis



**Figure 18 IN\_SET behavior during open load condition**

The N-1 status is latched. The output stages can be re-enabled by a Low to High transition at the EN pin or by a Power on reset. To provide a Limp Home functionality (lower number of LEDs instead of complete deactivation) in the case of a partially damaged LED array, the N-1 filter time  $t_{N-1}$  can be used. If a PWM signal with an ON-time of less than  $t_{N-1}$  is applied to the VS and EN pins, the N-1 detection feature will not be activated.

If there is more than one device used for N-1 detection the maximum number of devices, which can be connected as shown in [Figure 20](#) and [Figure 21](#), is limited to  $n_{N-1}$ . The maximum number of devices in N-1

## Load Diagnosis

configuration is calculated according to [Equation \(12\)](#), and the precondition of [Equation \(13\)](#) has to be fulfilled. The pull-down resistor  $R_{\text{PWMI}}$  is calculated according to [Equation \(14\)](#) and [Equation \(15\)](#).

$$n_{N-1} \leq \frac{\left( I_{\text{IN\_SET(OL,min)}} \cdot \frac{V_{\text{PWMI(H,max)}} + V_{\text{F}}}{R_{\text{SET(min)}}} \right) \cdot V_{\text{PWMI(H,min)}} \cdot R_{\text{SET(min)}}}{V_{\text{PWMI(H,max)}} \cdot 4 \cdot V_{\text{IN\_SET(max)}}} \quad (12)$$

$$\frac{V_{\text{PWMI(H,min)}} \cdot V_{\text{IN\_SET(min)}} \cdot R_{\text{SET(min)}}}{(V_{\text{IN\_SET(max)}})^2 \cdot R_{\text{SET(max)}}} > 1 \quad (13)$$

$$R_{\text{PWMI(min)}} = \frac{V_{\text{PWMI(H,max)}}}{I_{\text{IN\_SET(OL,min)}} - \frac{V_{\text{PWMI(H,max)}} + V_{\text{F}}}{R_{\text{SET(max)}}}} \quad (14)$$

$$R_{\text{PWMI(max)}} = \frac{V_{\text{PWMI(H,min)}}}{n_{N-1} \cdot 4 \cdot \frac{V_{\text{IN\_SET(max)}}}{R_{\text{SET(min)}}}} \quad (15)$$

$V_{\text{F}}$  represents the voltage drop across the diode between the IN\_SET- and the PWMI-pin.

*Note: If one channel of the device should not be used, the according output needs to be connected to GND, which leads to a disabling of this output.*

*Note: In case of a double fault, where the loads of two channels are faulty at the same time, the device operates as in normal operation. This feature is implemented to avoid any unwanted switch off during significant supply voltage drops. Please refer to [Chapter 9.2](#).*

## 9.2 Double Fault Conditions

The TLD1326EL has an integrated double fault detection feature. This feature is implemented to detect significant supply voltage drops. During such supply voltage drops close to the forward voltage of the LEDs the drivers outputs remain active. In case of load faults on two or more outputs within the time period  $t_{N-1}$  the device disables the diagnosis to avoid any uncorrect open load diagnosis during low supply voltages close to the forward voltages of the connected LED chains. If the faults between two or three channels happen with a delay of longer than  $t_{\text{OL}}$  the double fault detection feature is not active, i.e. the device is not turned on.

## 9.3 Electrical Characteristics IN\_SET Pin and Load Diagnosis

### Electrical Characteristics IN\_SET pin and Load Diagnosis

Unless otherwise specified:  $V_{\text{S}} = 5.5 \text{ V to } 40 \text{ V}$ ,  $T_{\text{j}} = -40^{\circ}\text{C to } +150^{\circ}\text{C}$ ,  $R_{\text{SET}} = 12 \text{ k}\Omega$ , all voltages with respect to ground, positive current flowing into pin for input pins (I), positive currents flowing out of the I/O and output pins (O) (unless otherwise specified)

Pos.	Parameter	Symbol	Limit Values			Unit	Conditions
			Min.	Typ.	Max.		
9.3.1	IN_SET reference voltage	$V_{\text{IN\_SET(ref)}}$	1.19	1.23	1.27	V	<sup>1)</sup> $V_{\text{OUTx}} = 3.6 \text{ V}$ $T_{\text{j}} = 25 \dots 115^{\circ}\text{C}$
9.3.2	IN_SET N_1 voltage	$V_{\text{IN\_SET(N-1)}}$	4	–	5.5	V	<sup>1)</sup> $V_{\text{S}} > 8 \text{ V}$ $T_{\text{j}} = 25 \dots 150^{\circ}\text{C}$ $V_{\text{S}} = V_{\text{OUTx}}(\text{OL})_{\text{x}}$

Load Diagnosis

Electrical Characteristics IN\_SET pin and Load Diagnosis (cont'd)

Unless otherwise specified:  $V_S = 5.5\text{ V}$  to  $40\text{ V}$ ,  $T_j = -40^\circ\text{C}$  to  $+150^\circ\text{C}$ ,  $R_{SET} = 12\text{ k}\Omega$ , all voltages with respect to ground, positive current flowing into pin for input pins (I), positive currents flowing out of the I/O and output pins (O) (unless otherwise specified)

Pos.	Parameter	Symbol	Limit Values			Unit	Conditions
			Min.	Typ.	Max.		
9.3.3	IN_SET N_1 voltage	$V_{IN\_SET(N-1)}$	3.2	–	5.5	V	<sup>1)</sup> $V_S = 5.5\text{ V}$ $T_j = 25\dots150\text{ }^\circ\text{C}$ $V_S = V_{OUTx}$ (OL)
9.3.4	IN_SET N_1 current	$I_{IN\_SET(N-1)}$	1.5	–	7.4	mA	<sup>1)</sup> $V_S > 8\text{ V}$ $T_j = 25\dots150\text{ }^\circ\text{C}$ $V_{IN\_SET} = 4\text{ V}$ $V_S = V_{OUTx}$ (OL)
9.3.5	N-1 high threshold	$V_{N-1(th)}$	2.45	2.85	3.2	V	$V_S > 8\text{ V}$
9.3.6	N-1 output current	$I_{N-1}$	12	20	28	$\mu\text{A}$	$V_S > 8\text{ V}$ $V_{N-1} = 2\text{ V}$
9.3.7	N-1 detection voltage $V_{PS(N-1)} = V_S - V_{OUTx}$	$V_{PS(N-1)}$	0.2	–	0.4	V	$V_S > 8\text{ V}$
9.3.8	IN_SET activation current without turn on of output stages	$I_{IN\_SET(act)}$	2	–	15	$\mu\text{A}$	See <b>Figure 15</b>

1) Not subject to production test, specified by design



Power Stage

## 10 Power Stage

The output stages are realized as high side current sources with a current of 120 mA. During off state the leakage current at the output stage is minimized in order to prevent a slightly glowing LED.

The maximum current of each channel is limited by the power dissipation and used PCB cooling areas (which results in the applications  $R_{thJA}$ ).

For an operating current control loop the supply and output voltages according to the following parameters have to be considered:

- Required supply voltage for current control  $V_{S(CC)}$ , **Pos. 6.3.8**
- Voltage drop over output stage during current control  $V_{PS(CC)}$ , **Pos. 10.2.6**
- Required output voltage for current control  $V_{OUTx(CC)}$ , **Pos. 10.2.7**

### 10.1 Protection

The device provides embedded protective functions, which are designed to prevent IC destruction under fault conditions described in this data sheet. Fault conditions are considered as “outside” normal operating range. Protective functions are neither designed for continuous nor for repetitive operation.

#### 10.1.1 Over Load Behavior

An over load detection circuit is integrated in the LITIX™ Basic IC. It is realized by a temperature monitoring of the output stages (OUTx).

As soon as the junction temperature exceeds the current reduction temperature threshold  $T_{j(CRT)}$  the output current will be reduced by the device by reducing the IN\_SET reference voltage  $V_{IN\_SET(ref)}$ . This feature avoids LED’s flickering during static output overload conditions. Furthermore, it protects LEDs against over temperature, which are mounted thermally close to the device. If the device temperature still increases, the three output currents decrease close to 0 A. As soon as the device cools down the output currents rise again.

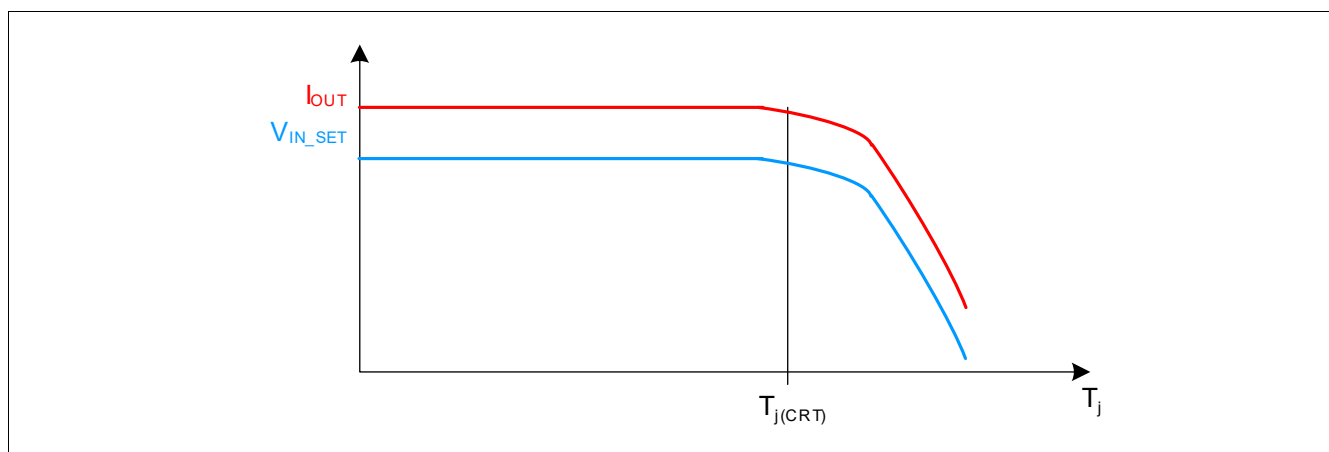

**Figure 19 Output current reduction at high temperature**

*Note: This high temperature output current reduction is realized by reducing the IN\_SET reference voltage (Pos. 9.3.1). In case of very high power loss applied to the device and very high junction temperature the output current may drop down to  $I_{OUTx} = 0$  mA, after a slight cooling down the current increases again.*

#### 10.1.2 Reverse Battery Protection

The TLD1326EL has an integrated reverse battery protection feature. This feature protects the driver IC itself, but also connected LEDs. The output reverse current is limited to  $I_{OUTx(rev)}$  by the reverse battery protection.

**Power Stage**

Note: Due to the reverse battery protection a reverse protection diode for the light module may be obsolete. In case of high ISO-pulse requirements and only minor protecting components like capacitors a reverse protection diode may be reasonable. The external protection circuit needs to be verified in the application.

**10.2 Electrical Characteristics Power Stage**

**Electrical Characteristics Power Stage**

Unless otherwise specified:  $V_S = 5.5\text{ V to }18\text{ V}$ ,  $T_j = -40^\circ\text{C to }+150^\circ\text{C}$ ,  $V_{OUTx} = 3.6\text{ V}$ , all voltages with respect to ground, positive current flowing into pin for input pins (I), positive currents flowing out of the I/O and output pins (O) (unless otherwise specified)

Pos.	Parameter	Symbol	Limit Values			Unit	Conditions
			Min.	Typ.	Max.		
10.2.1	Output leakage current	$I_{OUTx(leak)}$	-	-	7 3	$\mu\text{A}$	$V_{EN} = 5.5\text{ V}$ $I_{IN\_SET} = 0\ \mu\text{A}$ $V_{OUTx} = 2.5\text{ V}$ $T_j = 150^\circ\text{C}$ <sup>1)</sup> $T_j = 85^\circ\text{C}$
10.2.2	Output leakage current in boost over battery setup	$I_{OUTx(leak,B2B)}$	-	-	50	$\mu\text{A}$	<sup>1)</sup> $V_{EN} = 5.5\text{ V}$ $I_{IN\_SET} = 0\ \mu\text{A}$ $V_{OUTx} = V_S = 40\text{ V}$
10.2.3	Reverse output current	$-I_{OUTx(rev)}$	-	-	1	$\mu\text{A}$	<sup>1)</sup> $V_S = -16\text{ V}$ Output load: LED with break down voltage < -0.6 V
10.2.4	Output current accuracy limited temperature range	$k_{LT}$	697 645	750 750	803 855		<sup>1)</sup> $T_j = 25...115^\circ\text{C}$ $V_S = 8...18\text{ V}$ $V_{PS} = 2\text{ V}$ $R_{SET} = 6...12\text{ k}\Omega$ $R_{SET} = 30\text{ k}\Omega$
10.2.5	Output current accuracy over temperature	$k_{ALL}$	697 645	750 750	803 855		<sup>1)</sup> $T_j = -40...115^\circ\text{C}$ $V_S = 8...18\text{ V}$ $V_{PS} = 2\text{ V}$ $R_{SET} = 6...12\text{ k}\Omega$ $R_{SET} = 30\text{ k}\Omega$
10.2.6	Voltage drop over power stage during current control $V_{PS(CC)} = V_S - V_{OUTx}$	$V_{PS(CC)}$	0.75	-	-	V	<sup>1)</sup> $V_S = 13.5\text{ V}$ $R_{SET} = 12\text{ k}\Omega$ $I_{OUTx} \geq 90\%$ of $(k_{LT(typ)}/R_{SET})$
10.2.7	Required output voltage for current control	$V_{OUTx(CC)}$	2.3	-	-	V	<sup>1)</sup> $V_S = 13.5\text{ V}$ $R_{SET} = 12\text{ k}\Omega$ $I_{OUTx} \geq 90\%$ of $(k_{LT(typ)}/R_{SET})$

Power Stage

Electrical Characteristics Power Stage (cont'd)

Unless otherwise specified:  $V_S = 5.5\text{ V to }18\text{ V}$ ,  $T_j = -40^\circ\text{C to }+150^\circ\text{C}$ ,  $V_{\text{OUTx}} = 3.6\text{ V}$ , all voltages with respect to ground, positive current flowing into pin for input pins (I), positive currents flowing out of the I/O and output pins (O) (unless otherwise specified)

Pos.	Parameter	Symbol	Limit Values			Unit	Conditions
			Min.	Typ.	Max.		
10.2.8	Maximum output current	$I_{\text{OUT(max)}}$	120	–	–	mA	$R_{\text{SET}} = 4.7\text{ k}\Omega$ The maximum output current is limited by the thermal conditions. Please refer to <b>Pos. 4.3.1 - Pos. 4.3.3</b>
10.2.9	PWMI turn on time	$t_{\text{ON(PWMI)}}$	–	–	15	$\mu\text{s}$	<sup>2)</sup> $V_S = 13.5\text{ V}$ $R_{\text{SET}} = 12\text{ k}\Omega$ PWMI $\rightarrow$ L $I_{\text{OUTx}} = 80\%$ of $(k_{\text{LT(typ)}}/R_{\text{SET}})$
10.2.10	PWMI turn off time	$t_{\text{OFF(PWMI)}}$	–	–	10	$\mu\text{s}$	<sup>2)</sup> $V_S = 13.5\text{ V}$ $R_{\text{SET}} = 12\text{ k}\Omega$ PWMI $\rightarrow$ H $I_{\text{OUTx}} = 20\%$ of $(k_{\text{LT(typ)}}/R_{\text{SET}})$
10.2.11	IN_SET turn on time	$t_{\text{ON(IN\_SET)}}$	–	–	15	$\mu\text{s}$	$V_S = 13.5\text{ V}$ $I_{\text{IN\_SET}} = 0 \rightarrow 100\text{ }\mu\text{A}$ $I_{\text{OUTx}} = 80\%$ of $(k_{\text{LT(typ)}}/R_{\text{SET}})$
10.2.12	IN_SET turn off time	$t_{\text{OFF(IN\_SET)}}$	–	–	10	$\mu\text{s}$	$V_S = 13.5\text{ V}$ $I_{\text{IN\_SET}} = 100 \rightarrow 0\text{ }\mu\text{A}$ $I_{\text{OUTx}} = 20\%$ of $(k_{\text{LT(typ)}}/R_{\text{SET}})$
10.2.13	VS turn on time	$t_{\text{ON(VS)}}$	–	–	20	$\mu\text{s}$	<sup>1) 3)</sup> $V_{\text{EN}} = 5.5\text{ V}$ $R_{\text{SET}} = 12\text{ k}\Omega$ $V_S = 0 \rightarrow 13.5\text{ V}$ $I_{\text{OUTx}} = 80\%$ of $(k_{\text{LT(typ)}}/R_{\text{SET}})$
10.2.14	Current reduction temperature threshold	$T_{\text{j(CRT)}}$	–	140	–	$^\circ\text{C}$	<sup>1)</sup> $I_{\text{OUTx}} = 95\%$ of $(k_{\text{LT(typ)}}/R_{\text{SET}})$
10.2.15	Output current during current reduction at high temperature	$I_{\text{OUT(CRT)}}$	85% of $(k_{\text{LT(typ)}}/R_{\text{SET}})$	–	–	A	<sup>1)</sup> $R_{\text{SET}} = 12\text{ k}\Omega$ $T_j = 150\text{ }^\circ\text{C}$

1) Not subject to production test, specified by design

2) see also **Figure 8**

3) see also **Figure 6**

Application Information

11 Application Information

Note: The following information is given as a hint for the implementation of the device only and shall not be regarded as a description or warranty of a certain functionality, condition or quality of the device.

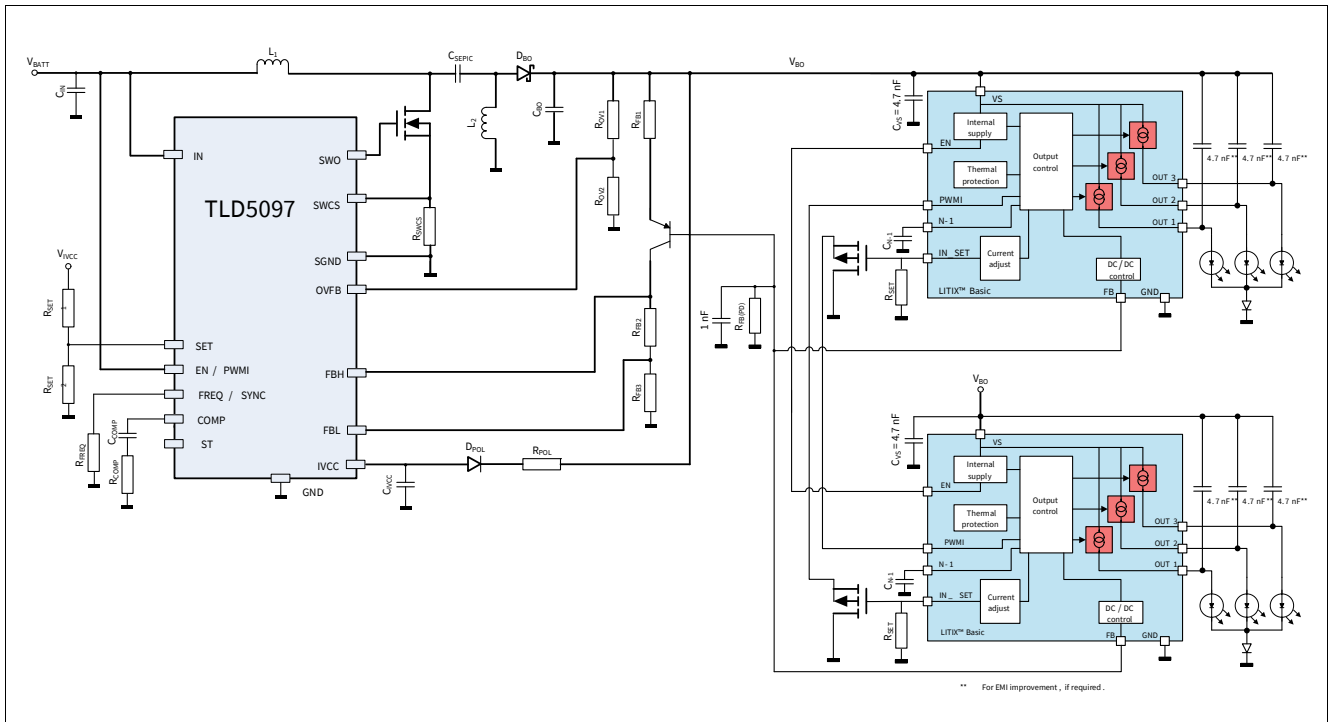

Figure 20 System diagram DC/DC control SEPIC + N-1 detection

Application Information

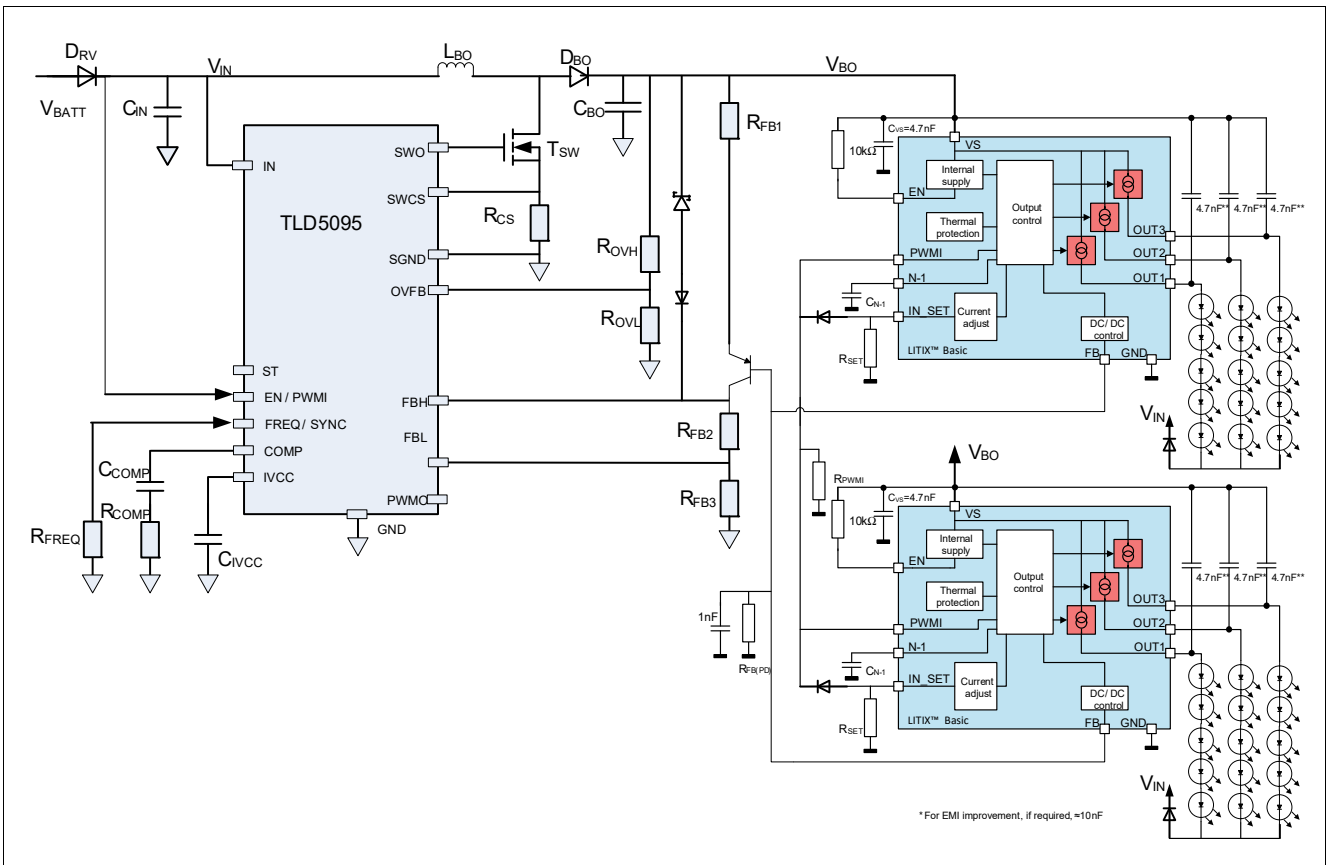

Figure 21 System diagram DC/DC control Boost + N-1 detection

Note: This is a very simplified example of an application circuit. The function must be verified in the real application.

11.1 Further Application Information

- For further information you may contact <http://www.infineon.com/>

## 12 Package Outlines

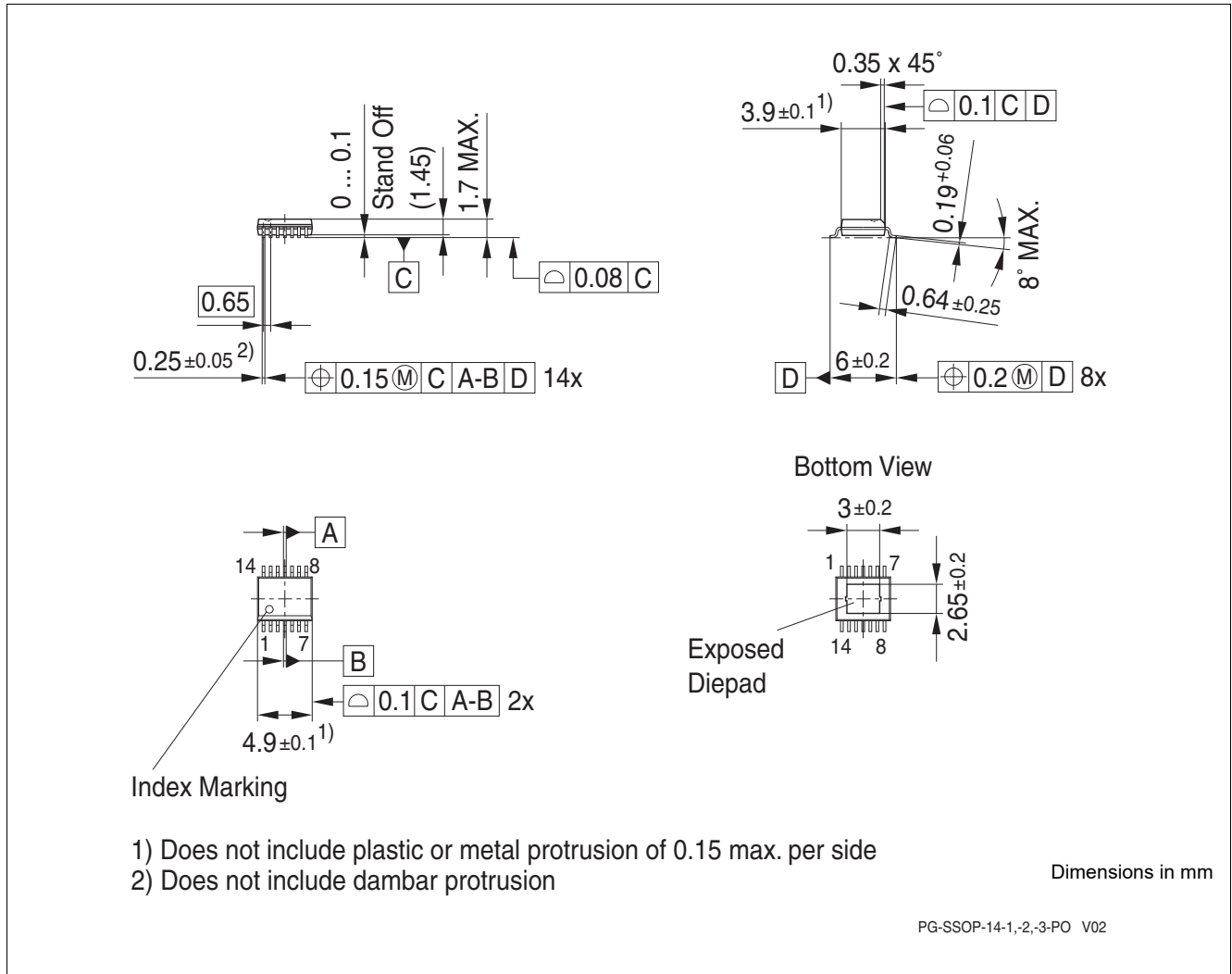

Figure 22 PG-SSOP-14

### Green Product (RoHS compliant)

To meet the world-wide customer requirements for environmentally friendly products and to be compliant with government regulations the device is available as a green product. Green products are RoHS-Compliant (i.e Pb-free finish on leads and suitable for Pb-free soldering according to IPC/JEDEC J-STD-020).

For further information on alternative packages, please visit our website:  
<http://www.infineon.com/packages>.

Revision History

## 13 Revision History

Revision	Date	Changes
1.0	2013-08-08	Initial revision of data sheet
1.1	2015-03-19	Updated parameters $K_{LT}$ and $K_{ALL}$ in the chapter Power Stage
1.2	2018-04-26	Updated to latest template
1.2	2018-04-26	Updated application drawing
1.2	2018-04-26	Updated package marking
1.2	2018-04-26	Updated package figure
1.2	2018-04-26	Updated <b>Chapter 7.1</b>
1.2	2018-04-26	Updated <b>Figure 20</b>

## Table of Contents

<b>1</b>	<b>Overview</b> .....	<b>1</b>
<b>2</b>	<b>Block Diagram</b> .....	<b>3</b>
<b>3</b>	<b>Pin Configuration</b> .....	<b>4</b>
3.1	Pin Assignment .....	4
3.2	Pin Definitions and Functions .....	5
<b>4</b>	<b>General Product Characteristics</b> .....	<b>6</b>
4.1	Absolute Maximum Ratings .....	6
4.2	Functional Range .....	7
4.3	Thermal Resistance .....	7
<b>5</b>	<b>EN Pin</b> .....	<b>8</b>
5.1	EN Function .....	8
5.2	Internal Supply Pin .....	9
5.3	EN Unused .....	10
5.3.1	EN - Pull Up to VS .....	10
5.3.2	EN - Direct Connection to VS .....	10
<b>6</b>	<b>PWMI Pin</b> .....	<b>11</b>
6.1	PWM Dimming .....	11
6.2	Internal PWM Unit .....	12
6.3	Electrical Characteristics Internal Supply / EN / PWMI Pin .....	13
<b>7</b>	<b>FB Pin</b> .....	<b>16</b>
7.1	DC/DC Control .....	16
7.2	Electrical Characteristics FB Pin .....	17
<b>8</b>	<b>IN_SET Pin</b> .....	<b>18</b>
8.1	Output Current Adjustment via RSET .....	18
8.2	Smart Input Pin .....	18
<b>9</b>	<b>Load Diagnosis</b> .....	<b>21</b>
9.1	N-1 Detection .....	21
9.2	Double Fault Conditions .....	23
9.3	Electrical Characteristics IN_SET Pin and Load Diagnosis .....	23
<b>10</b>	<b>Power Stage</b> .....	<b>25</b>
10.1	Protection .....	25
10.1.1	Over Load Behavior .....	25
10.1.2	Reverse Battery Protection .....	25
10.2	Electrical Characteristics Power Stage .....	26
<b>11</b>	<b>Application Information</b> .....	<b>28</b>
11.1	Further Application Information .....	29
<b>12</b>	<b>Package Outlines</b> .....	<b>30</b>
<b>13</b>	<b>Revision History</b> .....	<b>31</b>
	<b>Table of Contents</b> .....	<b>32</b>



## Trademarks

All referenced product or service names and trademarks are the property of their respective owners.

**Edition 2018-04-26**

**Published by**

**Infineon Technologies AG**

**81726 Munich, Germany**

**© 2018 Infineon Technologies AG.**

**All Rights Reserved.**

**Do you have a question about any aspect of this document?**

**Email: [erratum@infineon.com](mailto:erratum@infineon.com)**

**Document reference**

**TLD1326EL**

## IMPORTANT NOTICE

The information given in this document shall in no event be regarded as a guarantee of conditions or characteristics ("Beschaffheitsgarantie").

With respect to any examples, hints or any typical values stated herein and/or any information regarding the application of the product, Infineon Technologies hereby disclaims any and all warranties and liabilities of any kind, including without limitation warranties of non-infringement of intellectual property rights of any third party.

In addition, any information given in this document is subject to customer's compliance with its obligations stated in this document and any applicable legal requirements, norms and standards concerning customer's products and any use of the product of Infineon Technologies in customer's applications.

The data contained in this document is exclusively intended for technically trained staff. It is the responsibility of customer's technical departments to evaluate the suitability of the product for the intended application and the completeness of the product information given in this document with respect to such application.

For further information on technology, delivery terms and conditions and prices, please contact the nearest Infineon Technologies Office ([www.infineon.com](http://www.infineon.com)).

## WARNINGS

Due to technical requirements products may contain dangerous substances. For information on the types in question please contact your nearest Infineon Technologies office.

Except as otherwise explicitly approved by Infineon Technologies in a written document signed by authorized representatives of Infineon Technologies, Infineon Technologies' products may not be used in any applications where a failure of the product or any consequences of the use thereof can reasonably be expected to result in personal injury.